



# NPA Message Sequence Diagrams

Version 1.1.0

23<sup>rd</sup> June 2023

Classification: Public

# Contents

1	Documentation Information	4
1.1	Version history	4
1.2	Copyright statement	4
1.3	Change History	5
2	Introduction	8
3	Overview – NPA Message Sequence Diagrams	9
3.1	Glossary of Terms – Message Sequence Diagram Roles and Submission Types	9
3.2	Payment Flow Categorisation	9
3.2.1	Payment Flow Categorisation (up to Level 3)	10
3.2.2	Payment Flow Categorisation (up to Level 4 Single)	10
3.2.3	Payment Flow Categorisation (up to Level 4 Multi/File)	11
4	NPA CIS Message Sequence Diagrams	12
4.1	Group A - Single	12
4.1.1	Single Immediate Payment instruction submitted by DSP/DNSP - Accepted (A.1.1.1)	12
4.1.2	Single SOP/FDP instruction submitted by DSP/DNSP – Accepted (A.1.1.1)	13
4.1.3	Single Immediate Payment instruction submitted by DSP/DNSP - Conditionally Accepted (A.1.1.2)	14
4.1.4	Single Immediate Payment instruction submitted by DSP/DNSP – Rejected by NPA CIS due to Technical reasons (A.1.1.3)	15
4.1.5	Single Immediate Payment instruction submitted by DSP/DNSP – Rejected by NPA CIS due to Business reasons (A.1.1.4)	16
4.1.6	Single Immediate Payment instruction submitted by DSP/DNSP – Rejected by NPA CIS due to a Duplicate (A.1.1.4)	17
4.1.7	Single Immediate Payment instruction submitted by DSP/DNSP – NPA CIS ignores in-flight payment (A.1.1.4)	18
4.1.8	Single Immediate Payment instruction submitted by DSP/DNSP – NPA CIS rejection due to timeout (A.1.1.4)	19
4.1.9	Single Immediate Payment instruction submitted by DSP/DNSP – Rejected by Receiving Agent due to Technical reasons (A.1.1.5)	20
4.1.10	Single Immediate Payment instruction submitted by DSP/DNSP – Rejected by Receiving Agent due to Business reasons (A.1.1.6)	21
4.1.11	Single Immediate Payment instruction submitted by DSP/DNSP - Not received by the NPA CIS – Repeat (A.1.1.7)	22

4.1.12	Single Immediate Payment instruction submitted by DSP/DNSP - Payment Response not received by the Sending Agent – Repeat (A.1.1.7)	23
4.1.13	Single Immediate Payment instruction submitted by DSP/DNSP - Redirection by NPA CIS (CASS) (A.1.1.8)	24
4.1.14	Single Payment Return submitted by DSP/DNSP – Accepted (A.1.2.1)	25
4.1.15	Single Immediate Payment instruction submitted by TSP (DSP/DNSP) – Accepted (A.2.1.1)	26
4.1.16	Single Immediate Payment Initiation submitted by DS – Accepted (A.3.1.1)	27
4.1.17	Single FDP Payment Initiation submitted by DS – Accepted (A.3.1.1)	28
4.1.18	Single Immediate Payment Initiation submitted by DS – Conditionally Accepted (A.3.1.2)	29
4.1.19	Single Immediate Payment Initiation submitted by DS – Rejected by NPA CIS due to Technical reasons (A.3.1.3)	30
4.1.20	Single Immediate Payment Initiation submitted by DS – Rejected by NPA CIS due to Business reasons (A.3.1.4)	31
4.1.21	Single Immediate Payment Initiation submitted by DS – Rejected by NPA CIS due to a Duplicate (A.3.1.4)	32
4.1.22	Single Immediate Payment Initiation submitted by DS - NPA CIS ignores in-flight payment (A.3.1.4)	33
4.1.23	Single Immediate Payment Initiation submitted by DS – NPA CIS rejection due to timeout (A.3.1.4)	34
4.1.24	Single Immediate Payment Initiation submitted by DS – Rejected by Receiving Agent due to Technical reasons (A.3.1.5)	35
4.1.25	Single Immediate Payment Initiation submitted by DS – Rejected by Receiving Agent due to Business reasons (A.3.1.6)	36
4.1.26	Single Immediate Payment Initiation submitted by DS - Not received by the NPA CIS – Repeat (A.3.1.7)	37
4.1.27	Single Immediate Payment Initiation submitted by DS - Payment Initiation Response not received by the Direct Submitter – Repeat (A.3.1.7)	38
4.1.28	Single Immediate Payment Initiation submitted by TSP (DS) – Accepted (A.4.1.1)	39
4.2	Group B – Multi/File	40
4.2.1	Multi/File Immediate Payment Instruction submitted by DSP/DNSP – Accepted and Conditionally Accepted (B.1.1.1)	40
4.2.2	Multi/File SOP/FDP Payment Instruction submitted by DSP/DNSP – Accepted and Conditionally Accepted (B.1.1.1)	41

4.2.3	Multi/File Immediate Payment Instruction submitted by DSP/DNSP – Partially Accepted (B.1.1.2)	42
4.2.4	Multi/File Immediate Payment Instruction submitted by DSP/DNSP – Rejected by NPA CIS due to Technical reasons (B.1.1.3)	43
4.2.5	Multi/File Immediate Payment Instruction submitted by DSP/DNSP – Rejected by NPA CIS due to Business reasons (B.1.1.4)	44
4.2.6	Multi/File Immediate Payment Instruction submitted by TSP (DSP/DNSP) – Accepted (B.2.1.1)	45
4.2.7	Multi/File Immediate Payment Initiation submitted by DS – Accepted and Conditionally Accepted (B.3.1.1)	46
4.2.8	Multi/File FDP Payment Initiation submitted by DS – Accepted and Conditionally Accepted (B.3.1.1)	47
4.2.9	Multi/File Immediate Payment Initiation submitted by DS – Partially Accepted (B.3.1.2)	48
4.2.10	Multi/File Immediate Payment Initiation submitted by DS – Rejected by NPA CIS due to Technical reasons (B.3.1.3)	49
4.2.11	Multi/File Immediate Payment Initiation submitted by DS – Rejected by NPA CIS due to Business reasons (B.3.1.4)	50
4.2.12	Multi/File Immediate Payment Initiation submitted by TSP (DS) – Accepted (B.4.1.1)	51
4.3	Additional Scenarios	52
4.3.1	Single Status Request submitted by DSP/DNSP – Accepted	52
4.3.2	Multi/File Status Request submitted by DSP/DNSP – Accepted	53
4.3.3	Single Status Request submitted by DS – Accepted	54
4.3.4	Multi/File Status Request submitted by DS – Accepted	55
5	Appendix	56
5.1	Tables	56
5.2	Figures	56

# 1 Documentation Information

## 1.1 Version history

Version	Date	Description
V0.1	05/07/2021	First Draft – Collection 1
V0.2	06/12/2021	Second Draft – Collection 2
V0.3	09/05/2022	Third Draft – Collection 3
V1.0.0	31/01/2023	Message Standards Base Build V1.0.0
V1.1.0	23/06/2023	Message Standards Base Build V1.1.0

### Note:

This document corresponds to the June 2023 Standards (v.1.1.0) Release. For more details on this, and contextual information about the Message Sequence Diagrams, please see the Standards Message Implementation Guide which is hosted on the NPA [Standards Source Portal](#).

## 1.2 Copyright statement

© Copyright in this document lies with Pay.UK Limited. All rights reserved.

The copyright in this document is owned by Pay.UK Limited. All material, concepts and ideas detailed in this document are confidential to Pay.UK. This document shall not be used, disclosed or copied in whole or in part for any purposes unless specifically approved by Pay.UK.

## 1.3 Change History

Revised Version	Release Date	Description of Change	Reason for Change
V1.1.0	June'23	Align with Payment Scenarios instead of Use Cases	Use Cases are no longer used by the programme and there has been a shift towards use of 'Payment Scenarios', as seen in Customer Technical Specification version 2.1 (CTS v2.1), which are now reflected in the Message Sequence Diagrams.
V1.1.0	June'23	Provided Payment Scenario categories	Provide a categorisation scheme for the Message Sequence Diagrams to ensure completeness and provide a reference - categorised based on submission, participant, product and scenario type.
V1.1.0	June'23	Added New Scenarios - Payment Scenarios with Technical Services Participant (TSP) submission  Single/Multi/File Immediate Payment submitted by TSP (DSP/DNSP); Single/Multi/File Immediate Payment Initiation submitted by TSP (DS)	Added to show complete set of scenarios based on payment scenario categories.
V1.1.0	June'23	Added New Scenarios - Single Duplicate Payment scenarios  Single Immediate Payment instruction submitted by DSP/DNSP / Single Immediate Payment Initiation submitted by DS - Rejected by Receiving Agent due to a Duplicate; - NPA CIS ignores in-flight payment	Added to show complete set of scenarios based on payment scenario categories.

Revised Version	Release Date	Description of Change	Reason for Change
V1.1.0	June'23	<p>Added New Scenarios - Single Repeat Payment scenarios</p> <p>Single Immediate Payment instruction submitted by DSP/DNSP / Single Immediate Payment Initiation submitted by DS - Not received by the NPA CIS; - Payment Response not received by the Sending Agent</p>	Added to show complete set of scenarios based on payment scenario categories.
V1.1.0	June'23	<p>Added New Scenarios - Single Timeout Payment scenarios</p> <p>Single Immediate Payment instruction submitted by DSP/DNSP - NPA CIS rejection due to timeout; Single Immediate Payment Initiation submitted by DS - NPA CIS rejection due to timeout</p>	Added to show complete set of scenarios based on payment scenario categories.
V1.1.0	June'23	<p>Added New Scenarios - Payment Redirection scenario</p> <p>Single Immediate Payment instruction submitted by DSP/DNSP - Redirection by NPA CIS (CASS)</p>	Added generic sequence diagram to demonstrate the redirection scenario, which applies to other payment scenarios.
V1.1.0	June'23	<p>Added New Scenarios – Payment Status Request scenario; including Single/Multi/File for a DSP/DNSP/DS</p>	Added in four Payment Status Request sequence diagrams to cover some of the most common scenarios for different submission types and Participants. This list is non-exhaustive.
V1.1.0	June'23	<p>Altered Multi/File Scenario representation with X/Y and added two Receiving Agents</p>	Added in two payment instructions to Multi/File scenarios, represented as X/Y with two Receiving Agents, in order to demonstrate different status codes in the payment scenarios.

Revised Version	Release Date	Description of Change	Reason for Change
V1.1.0	June'23	Debtor Agent (Agency) and Creditor Agent (Agency) removed from Message Sequence Diagrams	No longer required to represent these roles in the payment scenarios and is aligned with programme deliverables.
V1.1.0	June'23	Instructing Agent and Instructed Agent (DCC) renamed to Direct Settling Participant/Direct Non-Settling Participant (DSP/DNSP)	Updated terminology through the programme.
V1.1.0	June'23	pac.002 Message exchange between NPA to Receiving Agent renamed from 'Payment Confirmation' to 'Payment Outcome'	Updated terminology through the programme.
V1.1.0	June'23	Renamed 'NPA' to 'NPA CIS' (NPA Central Infrastructure Services)	Updated terminology through the programme.
V1.1.0	June'23	Introduced the Transaction Status Codes in Single Payment messages - ACTC, ACWP, RJCT	Adding additional detail to the payment messages in each scenario to demonstrate the status code of the payment.
V1.1.0	June'23	Introduced the Group Status Codes in Multi/File Payment messages - ACTC, ACWP, PART, RJCT	Adding additional detail to the payment messages in each scenario to demonstrate the status code of the payment.

**Table 1: Change History for Message Sequence Diagrams**

## 2 Introduction

The Message Sequence Diagrams (MSD) provide a simple, chronological overview for developers and other interested parties on the flow of payment messages inbound to, and outbound from, the NPA Central Infrastructure Services (CIS).

The NPA Customer Technical Specification document (v2.1) has been used as one of the inputs and reference to create the Message Sequence Diagrams.

The MSDs highlight the selected ISO 20022 message sets for Message scenarios, their logical sequencing in a simple way, illustrating the flow of payment messages between Participants and the NPA CIS in a chronological sequence.

The V1.0.0 of the Message Sequence Diagrams, which were published as part of the Message Standards Base Build release (January 2023), have been uplifted based on various Participant feedback and to reflect the latest design decisions made by the NPA.

This document is intended for reference by potential Participants of the NPA, who will use this new ISO 20022 message standard. It is aimed at organisations and users who will implement the new standard for UK retail payments at a technical level, although other users of the NPA may find it useful.

## 3 Overview – NPA Message Sequence Diagrams

### 3.1 Glossary of Terms – Message Sequence Diagram Roles and Submission Types

The Message Sequence Diagrams and this document use a collection of terms to describe the roles of the parties involved. These terms, along with the different submission types for payments used in the NPA, are described below for reference alongside the Message Sequence Diagrams.

Term	Description
Sending Agent	The Clearing Participant that sends an instruction to NPA CIS (the sponsor of the debtor agent).
Receiving Agent	The Clearing Participant that receives an instruction from NPA CIS.
Clearing Participant	An organisation that executes payments using NPA. It can be a settling or non-settling participant: either a DSP or a DNSP.
Direct Settling Participant (DSP)	A financial institution that executes and settles payments using the NPA; it owns an NPA settlement account at the Bank of England.
Direct Non-Settling Participant (DNSP)	A financial institution that executes, but does not settle, payments using the NPA; settlement is performed by a Liquidity Services Sponsor (may be a DSP).
Direct Submitter (DS)	An organisation or government agency that initiates payments by submitting to the NPA. Payment initiation requests must be authorised by a sponsor.
Sponsoring Agent	The Clearing Participant that sponsors the submitting party.
Technical Services Participant (TSP)	An organisation that provides technology for a Clearing Participant or Direct Submitter to connect to NPA CIS for payment clearing and initiation.
NPA Central Infrastructure Services (NPA CIS)	The NPA Central Infrastructure Services (NPA CIS) is the NPA clearing system; it consists of core clearing and settlement services.
Single Submission	A single payment submission contains one payment instruction or return.
Multi/File Submission	A multi/file-payment submission contains more than one payment instruction.

**Table 2: Terms for Roles and Submission Types**

### 3.2 Payment Flow Categorisation

The Payment Flows within the NPA have logically been categorised into various levels as highlighted in the figure below based on the submission types, Participant's relationship with the NPA, Payment Products and the various scenarios associated within each category.

The NPA Payment Flows (Level 0) have been broadly categorised based on submission types (Level 1) – into Single and Multi/File. Payment flows have further been grouped by participant types (Level 2) based on their relationship with the NPA – DSP/DNSP, DS and payments submitted to the NPA via a TSP. Within participant types, the possible scenarios have been by categorised by payment product (Level 3) and associated with scenario types (Level 4).

The products reflected in this document are Immediate Payment (IMD), Standing Order Payment (SOP), Forward Dated Payment (FDP) and Payment Return.

This document also covers additional scenarios for a Status Request from a DSP/DNSP and DS.

### 3.2.1 Payment Flow Categorisation (up to Level 3)

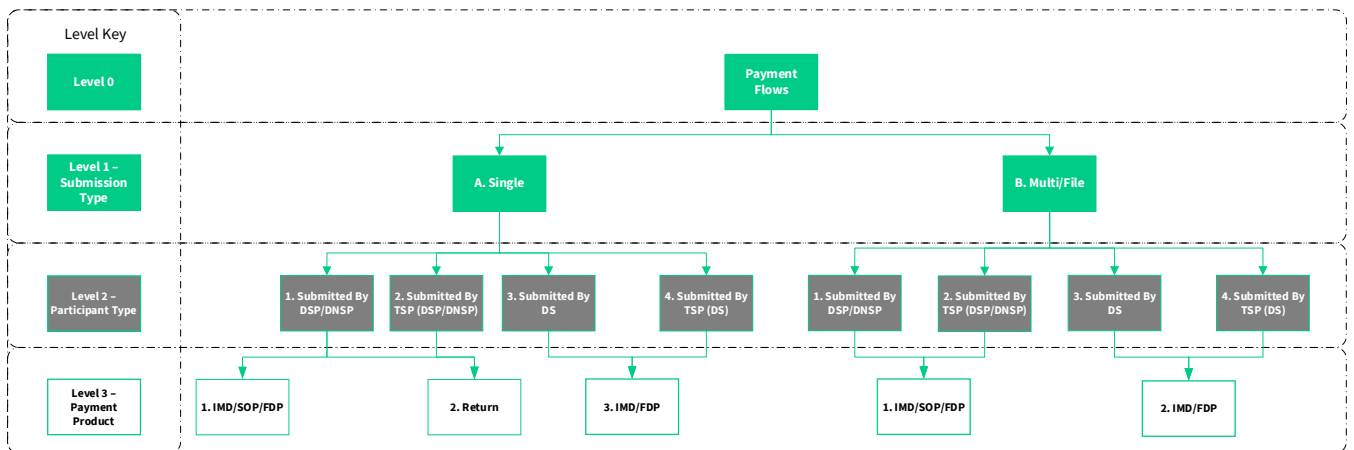

Figure 1: Payment Flow Categorisation Diagram (up to Level 3)

### 3.2.2 Payment Flow Categorisation (up to Level 4 Single)

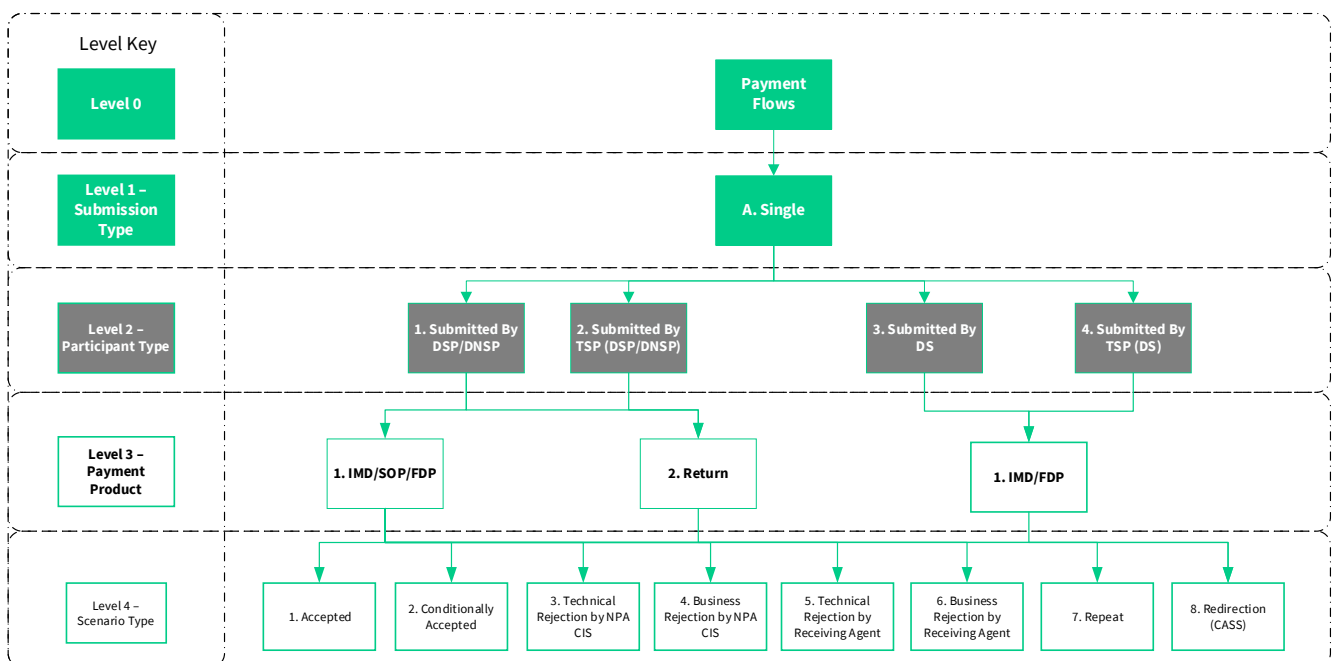
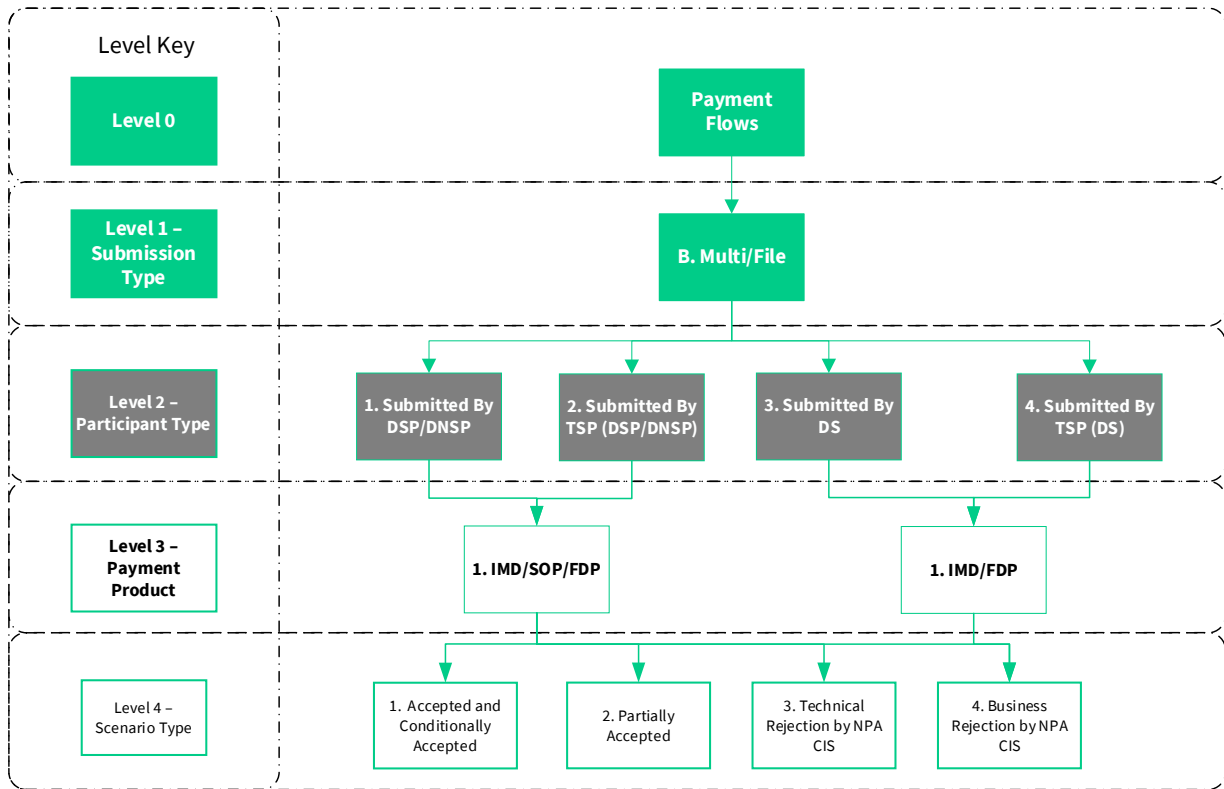

Figure 2: Payment Flow Categorisation Diagram (up to Level 4 Single)<sup>1</sup>

<sup>1</sup> The Scenario Types (Level 4) in this categorisation are to assist with the navigation and completeness of the scenarios in this document but is not an exhaustive list and there are scenarios which are mutually exclusive in this category level.

### 3.2.3 Payment Flow Categorisation (up to Level 4 Multi/File)



**Figure 3: Payment Flow Categorisation Diagram (up to Level 4 Multi/File)<sup>2</sup>**

<sup>2</sup> The Scenario Types (Level 4) in this categorisation are to assist with the navigation and completeness of the scenarios in this document but is not an exhaustive list and there are scenarios which are mutually exclusive in this category level.

## 4 NPA CIS Message Sequence Diagrams

### 4.1 Group A - Single

#### 4.1.1 Single Immediate Payment instruction submitted by DSP/DNSP - Accepted (A.1.1.1)

In this scenario, a Sending Agent submits a Single Immediate Payment instruction to the NPA CIS which is Accepted by the Receiving Agent.

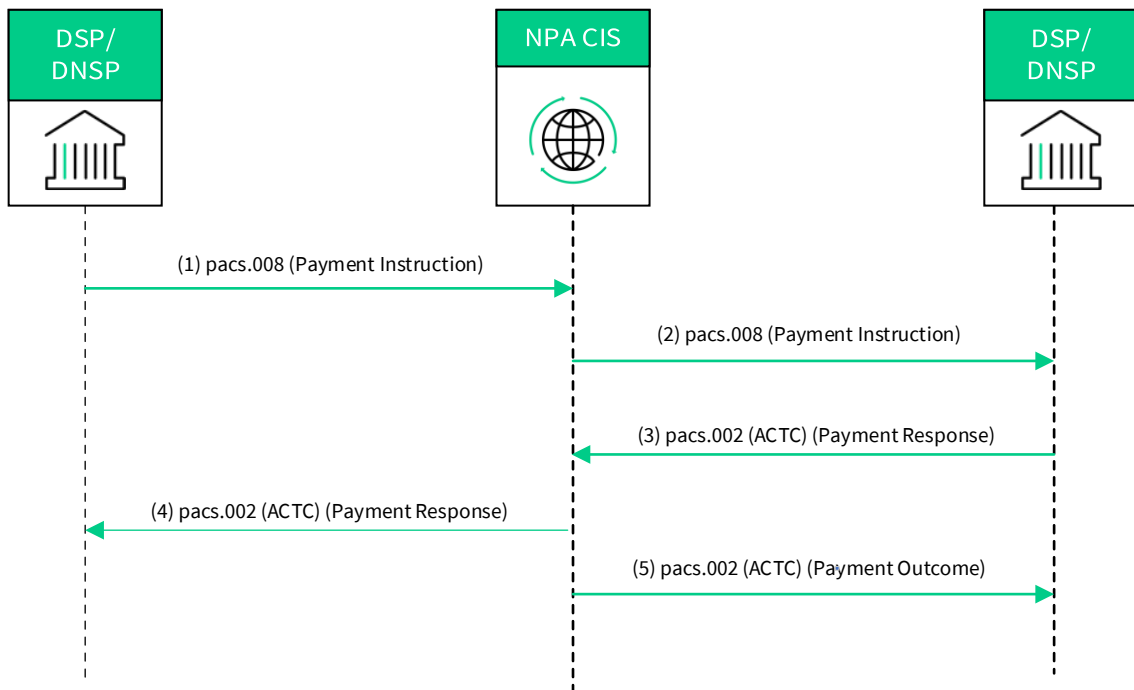

**Figure 4: Single Immediate Payment instruction submitted by DSP/DNSP - Accepted**

#### 4.1.2 Single SOP/FDP instruction submitted by DSP/DNSP – Accepted (A.1.1.1)

In this scenario, a Sending Agent submits a SOP/FDP instruction to the NPA CIS which is Accepted by the Receiving Agent.

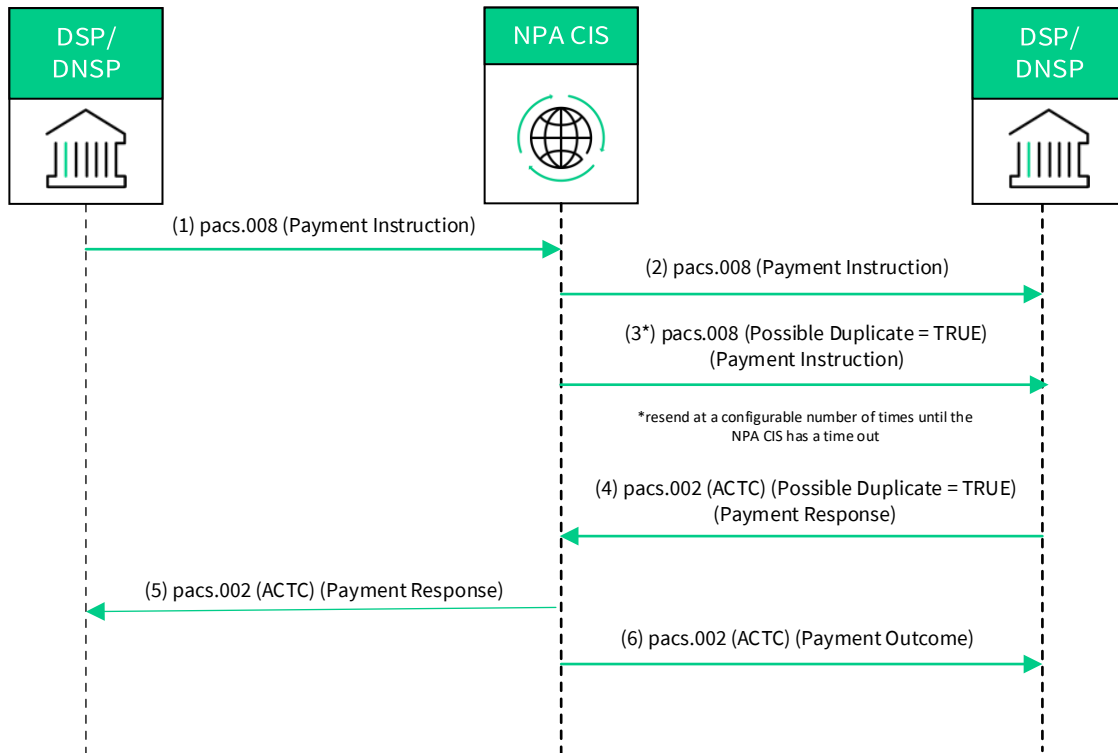

**Figure 5: Single SOP/FDP instruction submitted by DSP/DNSP – Accepted**

### 4.1.3 Single Immediate Payment instruction submitted by DSP/DNSP - Conditionally Accepted (A.1.1.2)

In this scenario, a Sending Agent submits a Single Immediate Payment instruction to the NPA CIS which is Conditionally Accepted by the Receiving Agent.

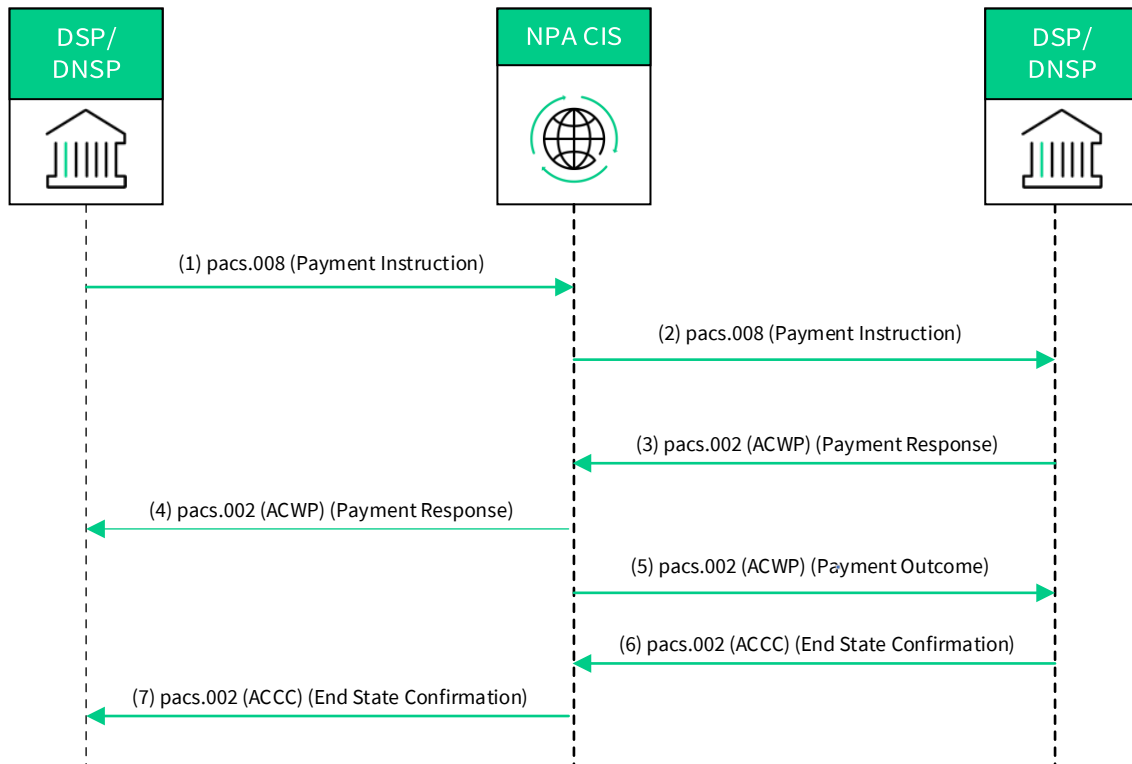

**Figure 6: Single Immediate Payment instruction submitted by DSP/DNSP - Conditionally Accepted**

#### 4.1.4 Single Immediate Payment instruction submitted by DSP/DNSP – Rejected by NPA CIS due to Technical reasons (A.1.1.3)

In this scenario, a Sending Agent submits a Single Immediate Payment instruction to the NPA CIS. The NPA CIS rejects the payment instruction due to technical validation reasons and sends out a technical rejection message to the Sending Agent.

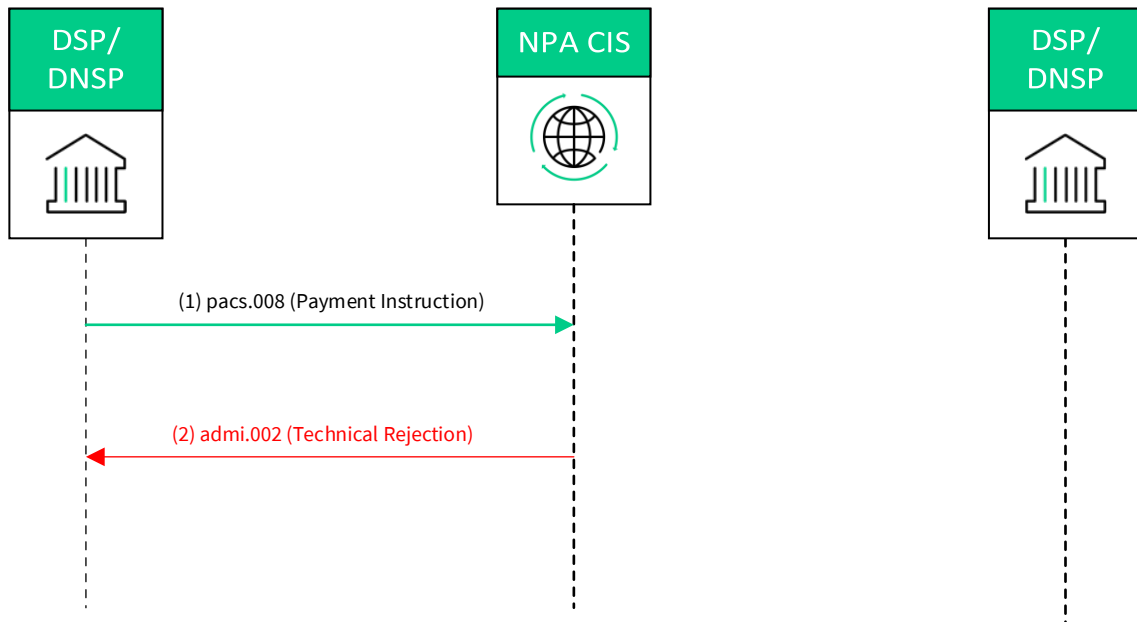

**Figure 7: Single Immediate Payment instruction submitted by DSP/DNSP – Rejected by NPA CIS due to Technical reasons**

#### 4.1.5 Single Immediate Payment instruction submitted by DSP/DNSP – Rejected by NPA CIS due to Business reasons (A.1.1.4)

In this scenario, a Sending Agent submits a Single Immediate Payment instruction to the NPA CIS. The NPA CIS rejects the payment instruction due to business validation reasons and sends out a rejection message to the Sending Agent.

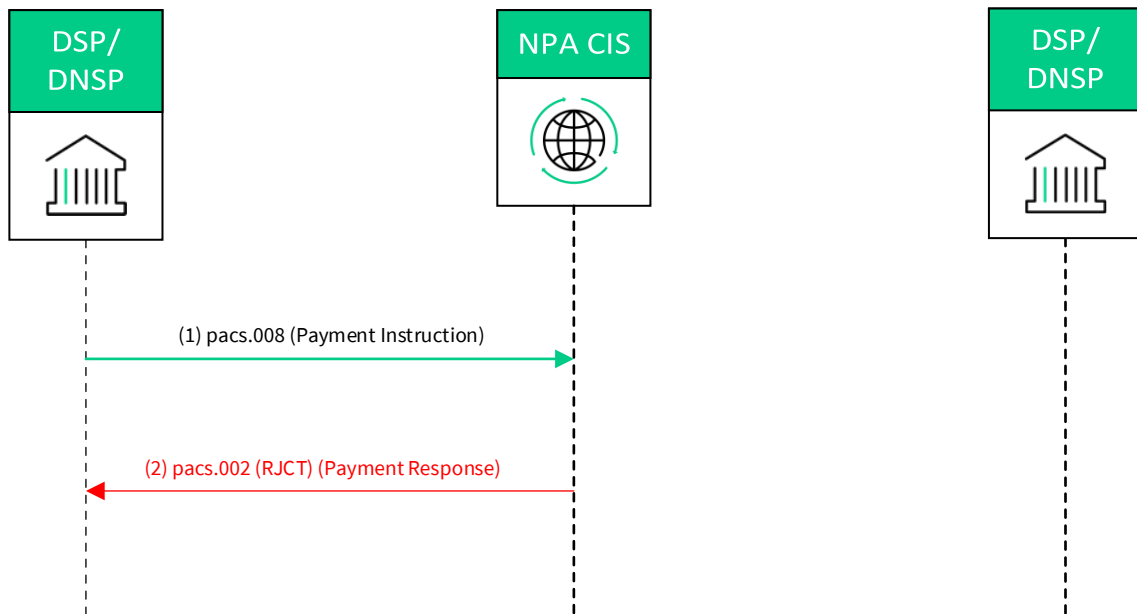

**Figure 8: Single Immediate Payment instruction submitted by DSP/DNSP – Rejected by NPA CIS due to Business reasons**

#### 4.1.6 Single Immediate Payment instruction submitted by DSP/DNSP – Rejected by NPA CIS due to a Duplicate (A.1.1.4)

In this scenario, a Sending Agent resends a previously submitted and accepted payment (without Possible Duplicate = TRUE). The NPA CIS sends out a rejection Payment Response message to the Sending Agent as the payment has already been processed.

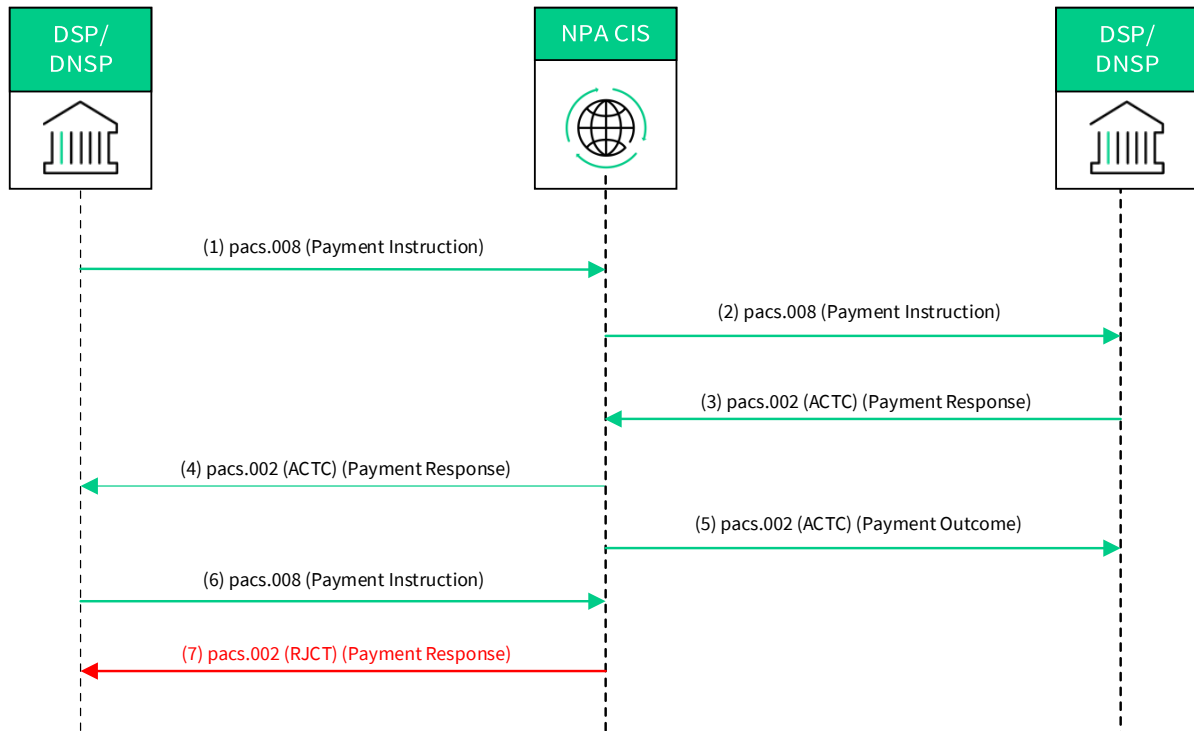

**Figure 9: Single Immediate Payment instruction submitted by DSP/DNSP – Rejected by NPA CIS due to a Duplicate**

#### 4.1.7 Single Immediate Payment instruction submitted by DSP/DNSP – NPA CIS ignores in-flight payment (A.1.1.4)

In this scenario, a Sending Agent resends a previously submitted payment which is still in-flight. The NPA CIS ignores the duplicate, processes the original payment instruction successfully and sends out a Payment Response to the Sending Agent.

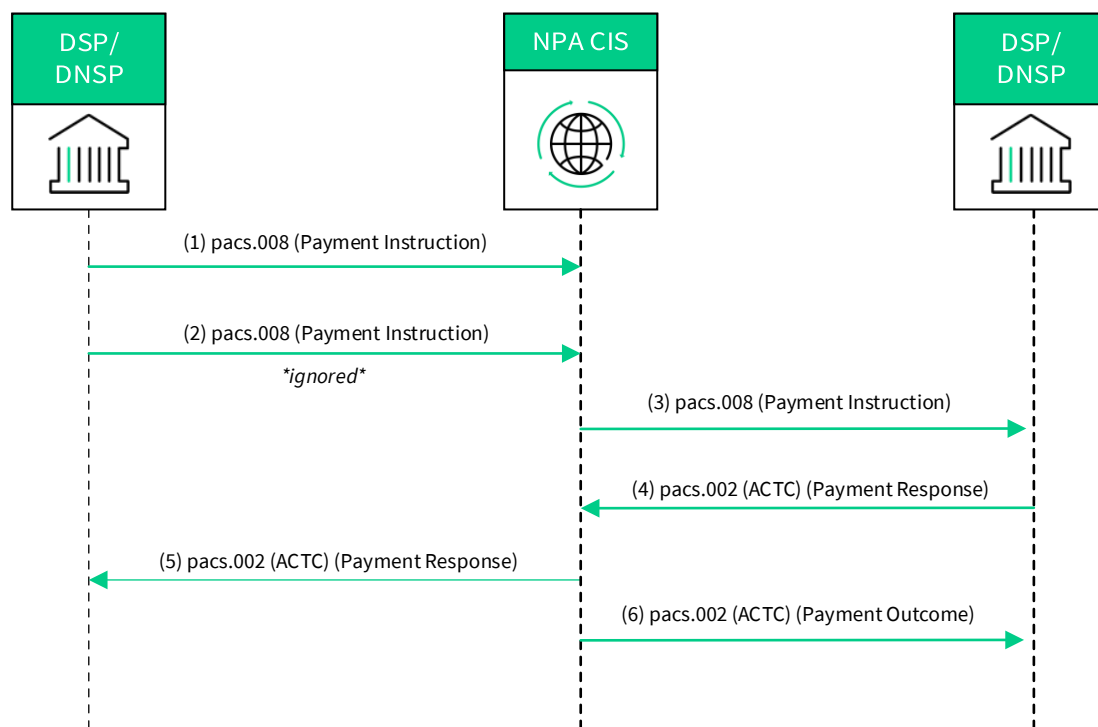

**Figure 10: Single Immediate Payment instruction submitted by DSP/DNSP – NPA CIS ignores in-flight payment**

#### 4.1.8 Single Immediate Payment instruction submitted by DSP/DNSP – NPA CIS rejection due to timeout (A.1.1.4)

In this scenario, no payment response is received from the Receiving Agent within the defined timeout period. The NPA CIS rejects the payment instruction and sends out a rejection Payment Response message to the Sending Agent and the Receiving Agent.

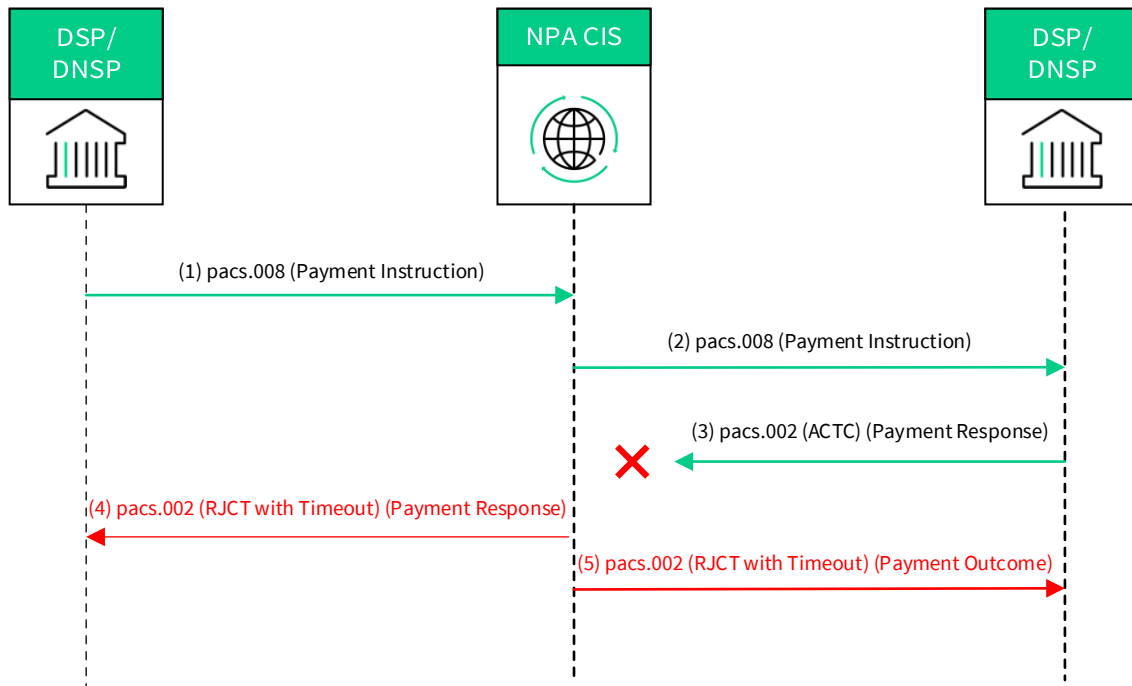

**Figure 11: Single Immediate Payment instruction submitted by DSP/DNSP – NPA CIS rejection due to timeout**

#### 4.1.9 Single Immediate Payment instruction submitted by DSP/DNSP – Rejected by Receiving Agent due to Technical reasons (A.1.1.5)

In this scenario, a Sending Agent sends a Payment Instruction to NPA CIS. The NPA CIS validates the payment instruction and sends it to the Receiving Agent. The Receiving Agent rejects the payment instruction due to technical validation reasons sends out a technical rejection message. The NPA CIS sends out a rejection Payment Response message to the Sending Agent and the Receiving Agent.

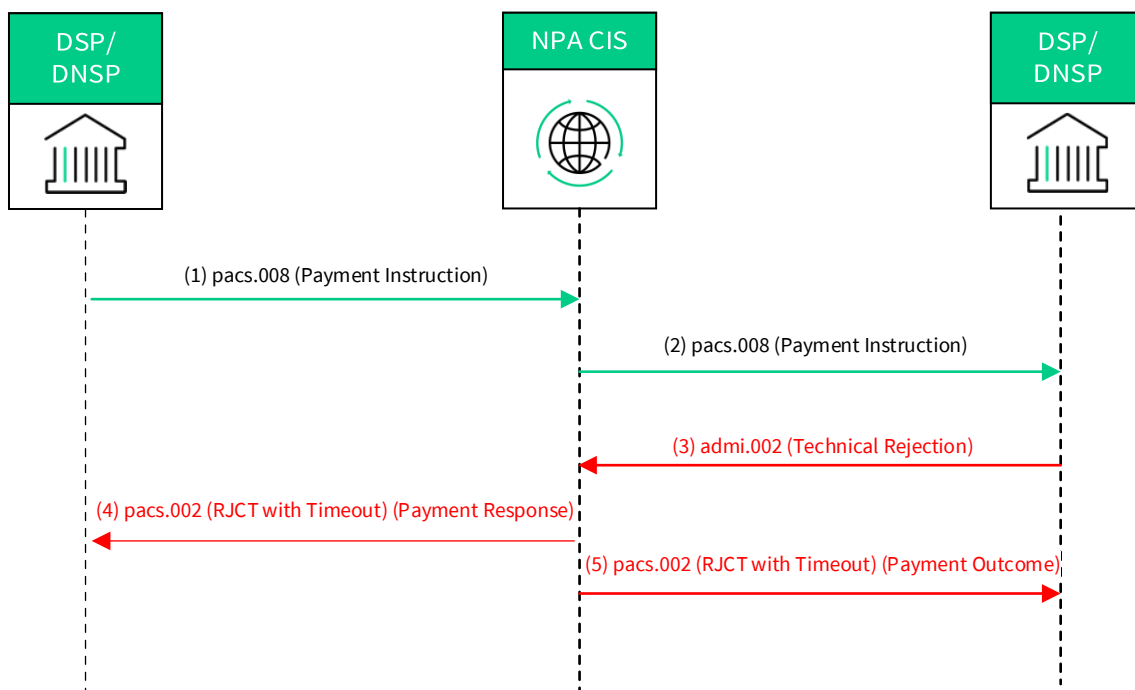

**Figure 12: Single Immediate Payment instruction submitted by DSP/DNSP – Rejected by Receiving Agent due to Technical reasons**

#### 4.1.10 Single Immediate Payment instruction submitted by DSP/DNSP – Rejected by Receiving Agent due to Business reasons (A.1.1.6)

In this scenario, a Sending Agent sends a single immediate payment instruction to NPA CIS. The NPA CIS validates the Payment instruction and sends it to the Receiving Agent. The Receiving Agent rejects the payment instruction due to business validation reasons. The NPA CIS sends out a rejection Payment Response message to the Sending Agent.

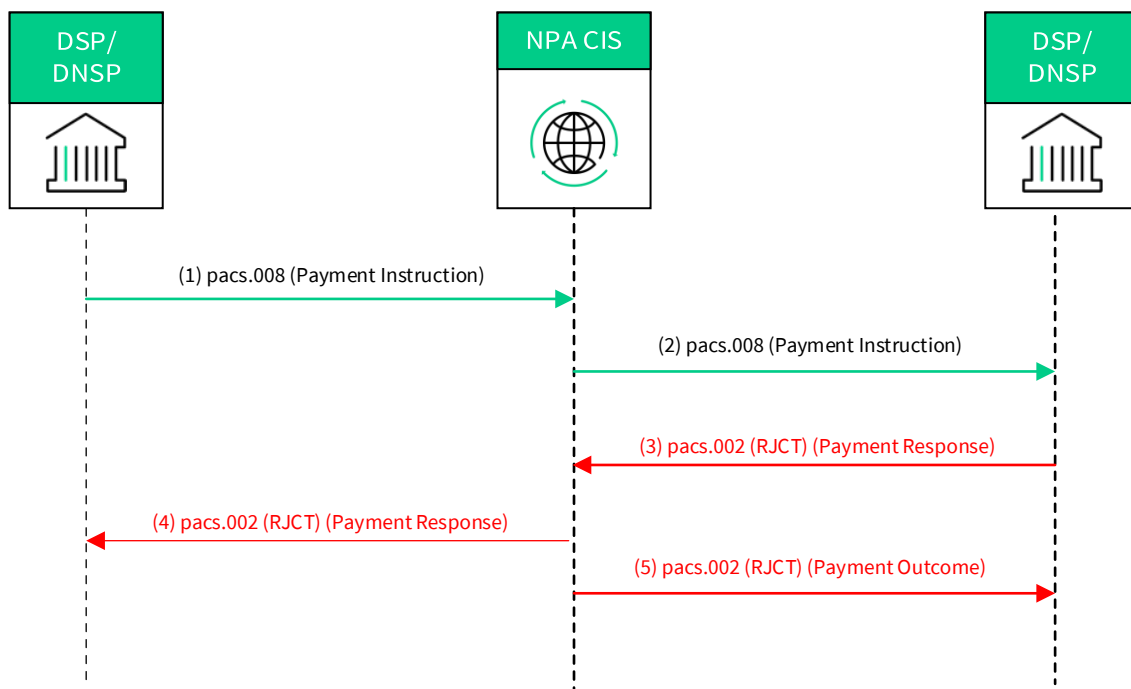

**Figure 13: Single Immediate Payment instruction submitted by DSP/DNSP Rejected by Receiving Agent due to Business reasons**

#### 4.1.11 Single Immediate Payment instruction submitted by DSP/DNSP - Not received by the NPA CIS - Repeat (A.1.1.7)

In this scenario, a single immediate payment instruction sent by the Sending Agent is not received by NPA CIS. The payment instruction is then resent by Sending Agent with “Possible Duplicate = TRUE” and processed successfully by NPA CIS.

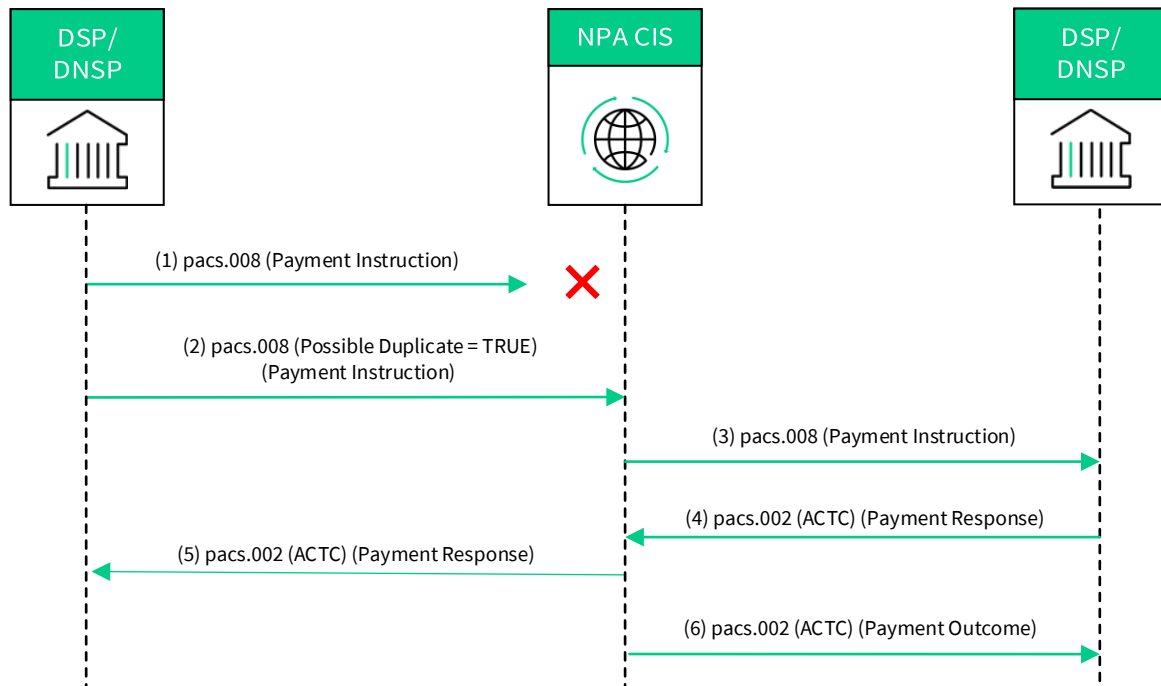

**Figure 14: Single Immediate Payment instruction submitted by DSP/DNSP - Not received by the NPA CIS - Repeat**

#### 4.1.12 Single Immediate Payment instruction submitted by DSP/DNSP - Payment Response not received by the Sending Agent – Repeat (A.1.1.7)

In this scenario, Sending Agent did not receive the Payment response sent by NPA CIS. The payment instruction is resent by Sending Agent with “Possible Duplicate = TRUE”. NPA CIS checks that the payment is processed and sends back the original Payment Response to the Sending Agent.

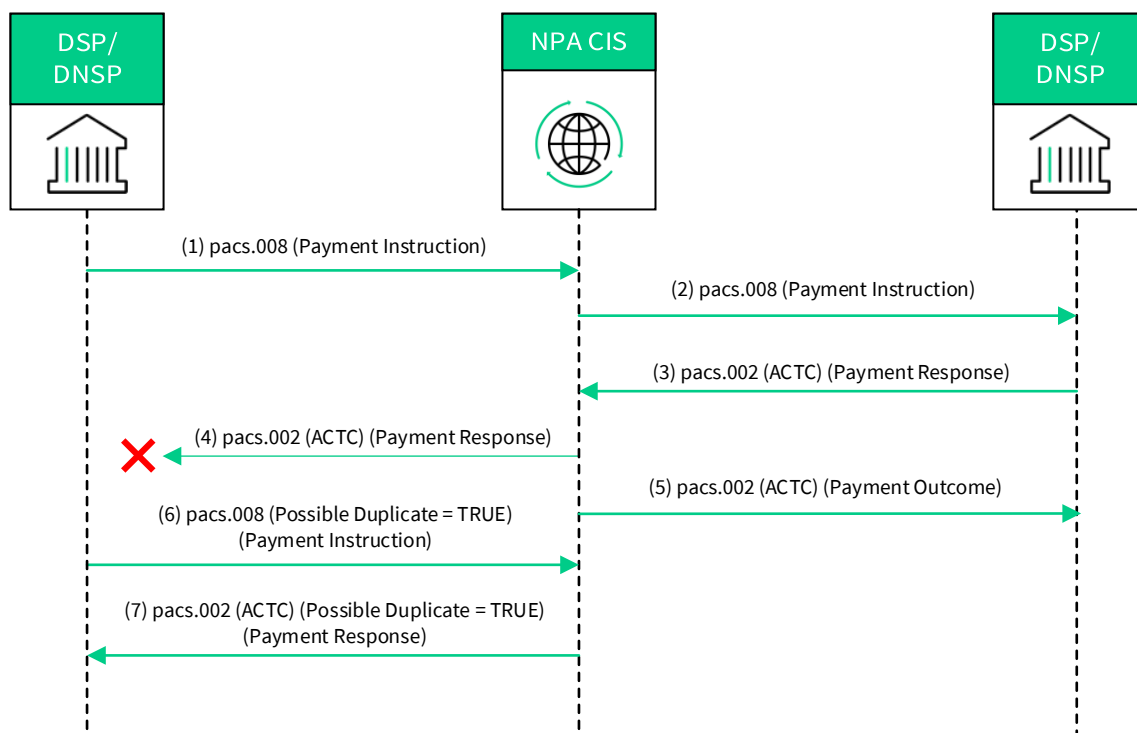

**Figure 15: Single Immediate Payment instruction submitted by DSP/DNSP - Payment Response not received by the Sending Agent – Repeat**

#### 4.1.13 Single Immediate Payment instruction submitted by DSP/DNSP - Redirection by NPA CIS (CASS) (A.1.1.8)

In this scenario, a Sending Agent sends a single immediate payment instruction to NPA CIS. The NPA CIS validates the Payment instruction and sends a redirection notification message to the Sending Agent. The NPA CIS then sends the single immediate payment instruction to the updated DSP/DNSP and the payment is processed accordingly. This payment scenario depicts a single immediate payment instruction but is representative of other payment scenarios including a redirection by the NPA CIS. They will all include an acmt.022 (Redirection Notification) from the NPA CIS following an instruction to the Sending Agent involving an updated Instructed Agent.

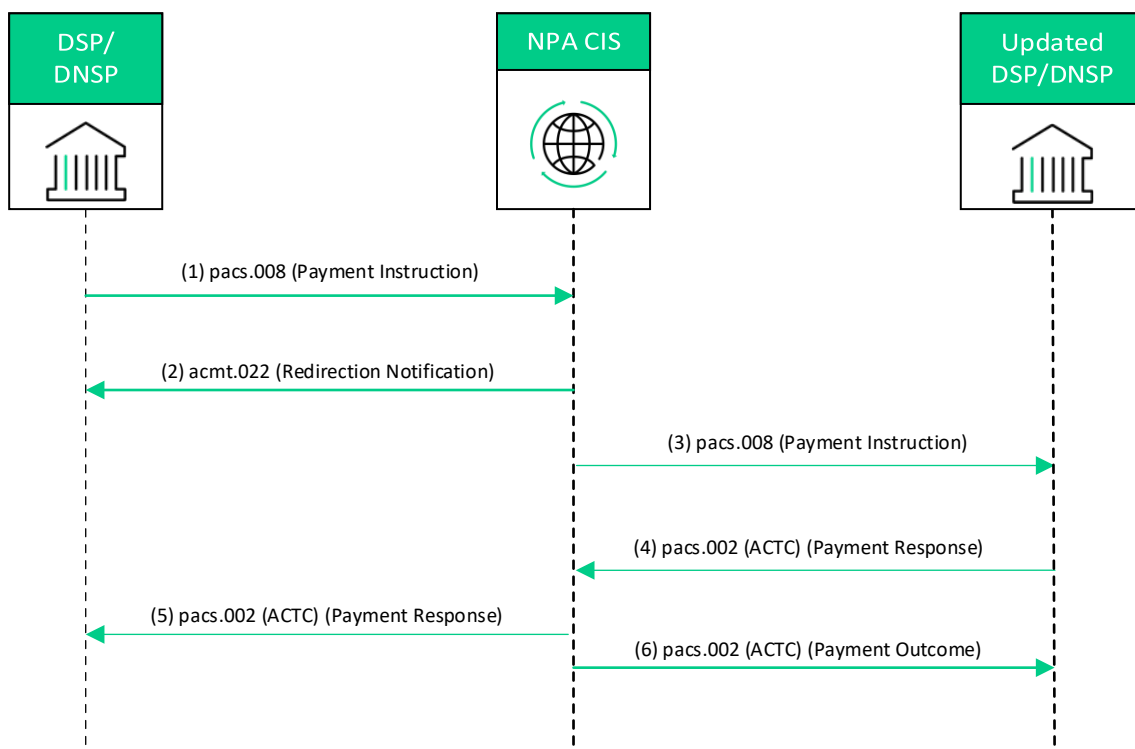

**Figure 16: Single Immediate Payment instruction submitted by DSP/DNSP - Redirection by NPA CIS (CASS)**

#### 4.1.14 Single Payment Return submitted by DSP/DNSP – Accepted (A.1.2.1)

In this scenario, a Sending Agent (the Receiving Agent of the original pacs.008 Payment Instruction) submits a Single Payment Return to NPA CIS which is Accepted by the Receiving Agent (the Sending Agent of the original pacs.008 Payment Instruction).

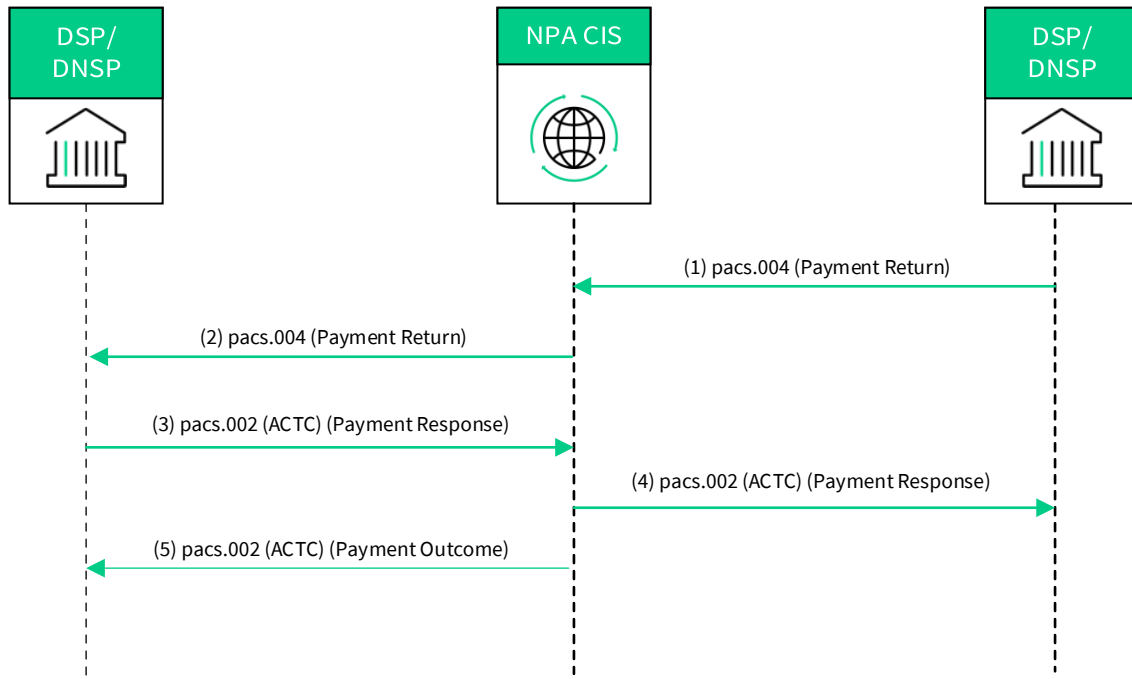

**Figure 17: Single Payment Return submitted by DSP/DNSP – Accepted**

#### 4.1.15 Single Immediate Payment instruction submitted by TSP (DSP/DNSP) – Accepted (A.2.1.1)

In this scenario, a Sending Agent submits a single immediate payment instruction to the NPA CIS via a TSP which is Accepted by the Receiving Agent.

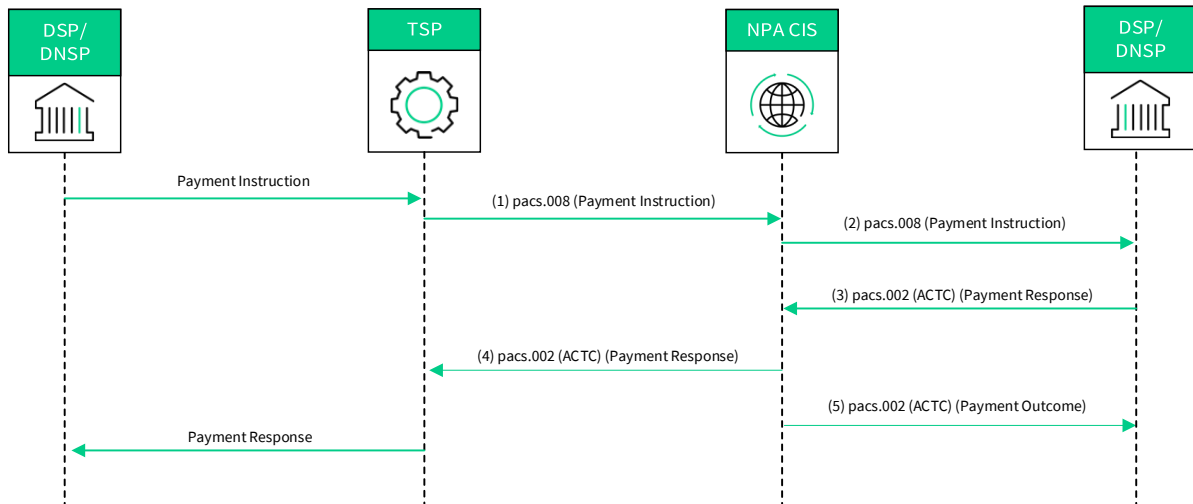

**Figure 18: Single Immediate Payment instruction submitted by TSP (DSP/DNSP) – Accepted**

#### 4.1.16 Single Immediate Payment Initiation submitted by DS – Accepted (A.3.1.1)

In this scenario, a Direct Submitter submits a single immediate payment initiation message to the NPA CIS, which is authorised by their Sponsoring Agent. The NPA CIS translates the payment initiation message into payment instruction message(s) which is Accepted by the Receiving Agent.

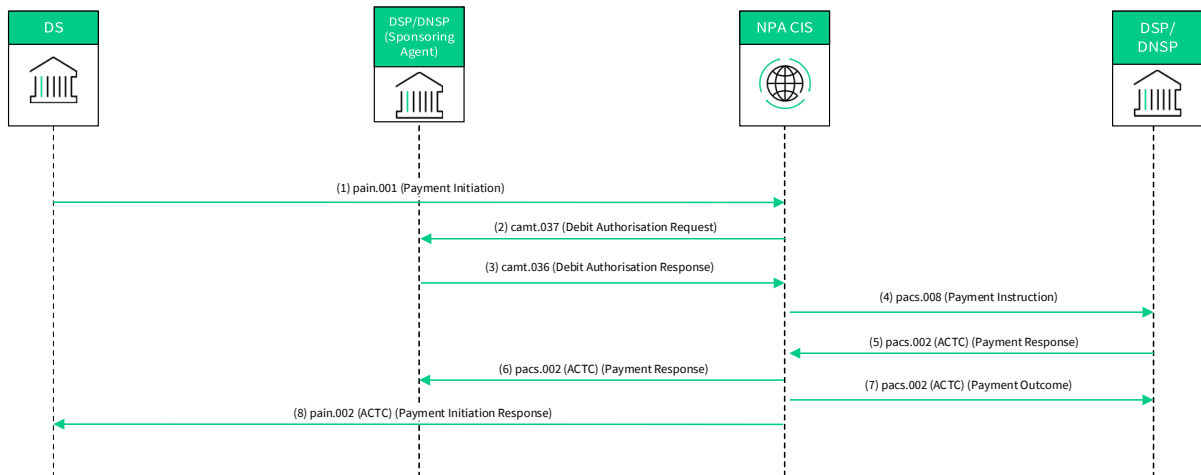

**Figure 19: Single Immediate Payment Initiation submitted by DS – Accepted**

#### 4.1.17 Single FDP Payment Initiation submitted by DS – Accepted (A.3.1.1)

In this scenario, a Direct Submitter submits a forward dated payment initiation message to the NPA CIS, which is authorised by their Sponsoring Agent. The NPA CIS translates the payment initiation message into payment instruction message(s) which is Accepted by the Receiving Agent.

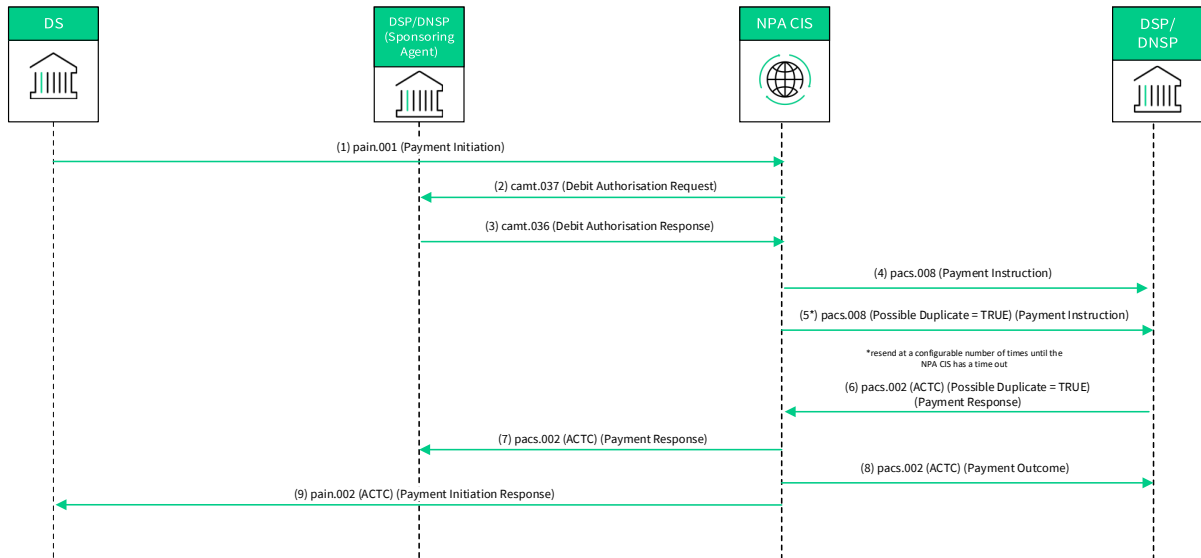

**Figure 20: Single FDP Payment Initiation submitted by DS – Accepted**

#### 4.1.18 Single Immediate Payment Initiation submitted by DS – Conditionally Accepted (A.3.1.2)

In this scenario, a Direct Submitter submits a single immediate payment initiation message to the NPA CIS, which is authorised by their Sponsoring Agent. The NPA CIS translates the payment initiation message into payment instruction message(s) which is Conditionally Accepted by the Receiving Agent.

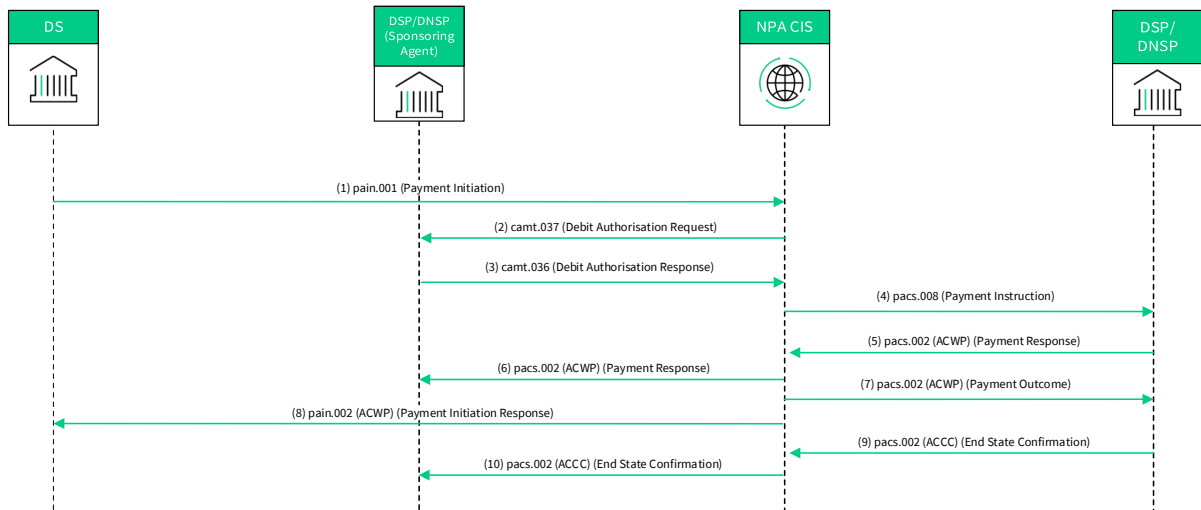

**Figure 21: Single Immediate Payment Initiation submitted by DS – Conditionally Accepted**

#### 4.1.19 Single Immediate Payment Initiation submitted by DS – Rejected by NPA CIS due to Technical reasons (A.3.1.3)

In this scenario, a Direct Submitter submits a single payment initiation message to the NPA CIS. The NPA CIS rejects the message due to technical validation reasons and sends out a technical rejection message to the Direct Submitter.

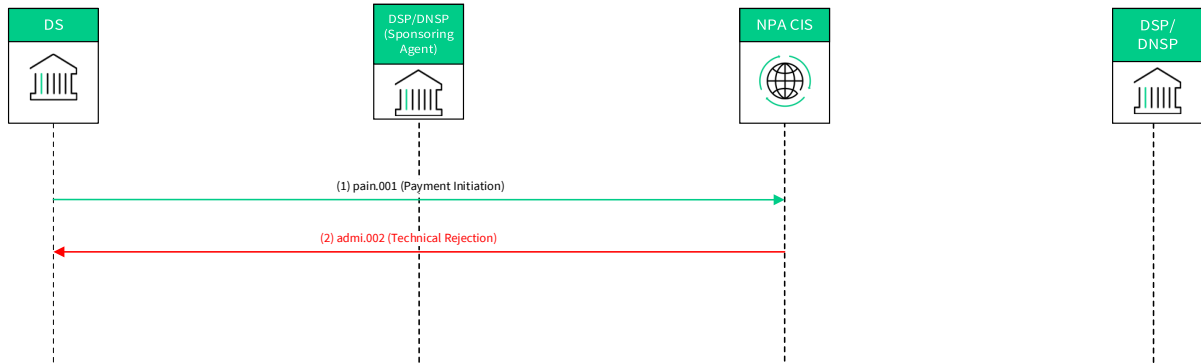

**Figure 22: Single Immediate Payment Initiation submitted by DS – Rejected by NPA CIS due to Technical reasons**

#### 4.1.20 Single Immediate Payment Initiation submitted by DS – Rejected by NPA CIS due to Business reasons (A.3.1.4)

In this scenario, a Direct Submitter submits a single payment initiation message to the NPA CIS. The NPA CIS rejects the message due to business validation reasons and sends out a rejection payment initiation response to the Direct Submitter.

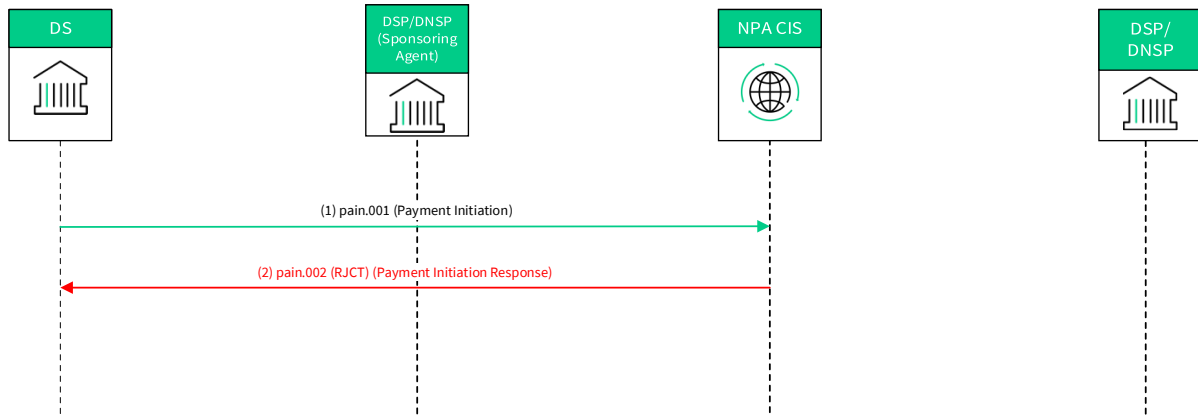

**Figure 23: Single Immediate Payment Initiation submitted by DS – Rejected by NPA CIS due to Business reasons**

#### 4.1.21 Single Immediate Payment Initiation submitted by DS – Rejected by NPA CIS due to a Duplicate (A.3.1.4)

In this scenario, a Direct Submitter resends a previously submitted and accepted payment initiation message (without Possible Duplicate = TRUE). The NPA CIS sends out a rejection Payment Initiation Response message to the Direct Submitter as the payment has already been processed.

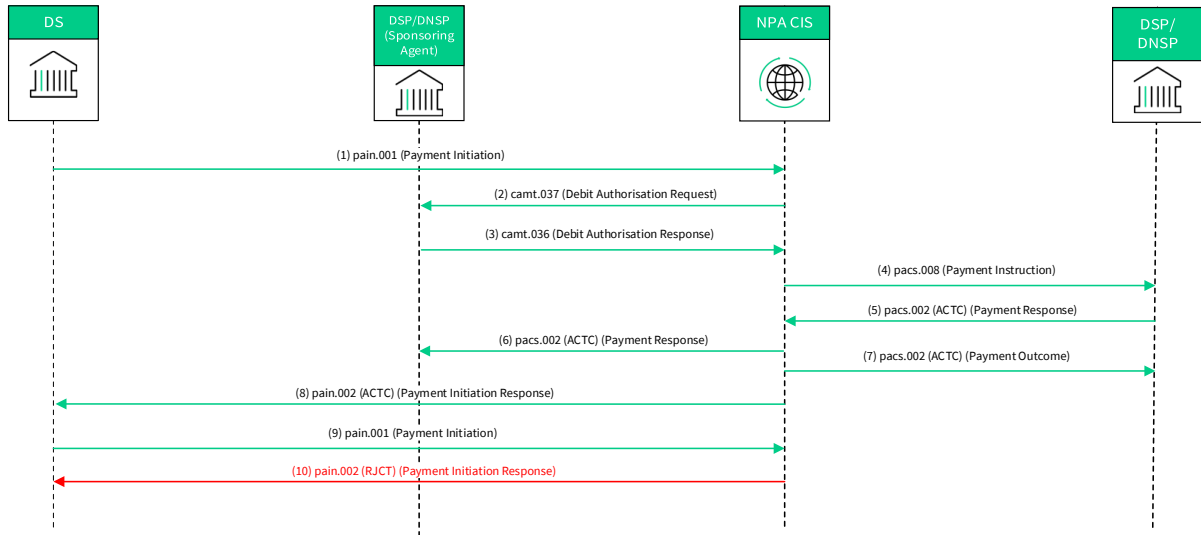

**Figure 24: Single Immediate Payment Initiation submitted by DS – Rejected by NPA CIS due to a Duplicate**

#### 4.1.22 Single Immediate Payment Initiation submitted by DS - NPA CIS ignores in-flight payment (A.3.1.4)

In this scenario, a Direct Submitter resends a previously submitted payment which is still in-flight. The NPA CIS ignores the duplicate, processes the original payment initiation message successfully and sends out a Payment Initiation Response to Direct Submitter.

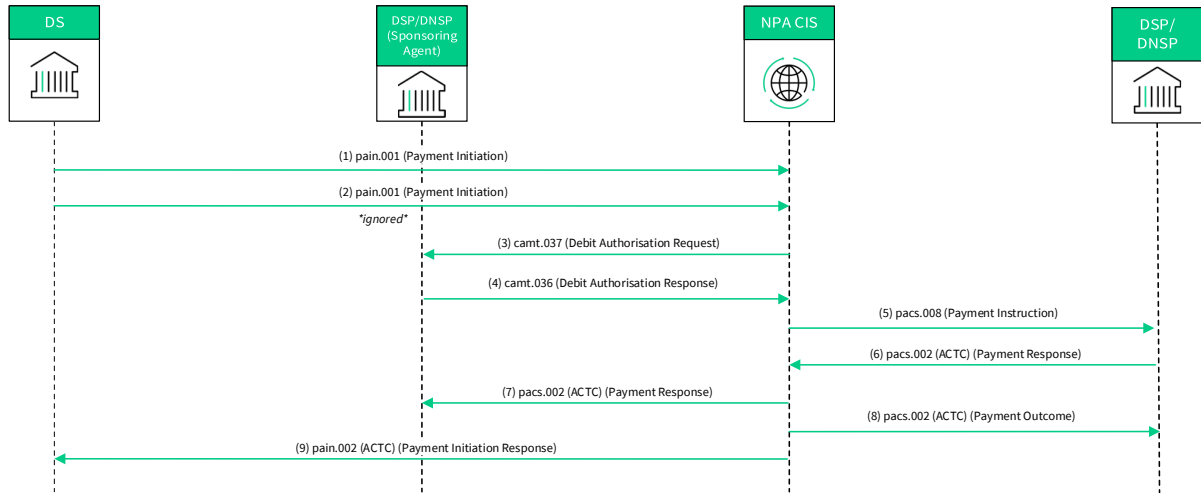

**Figure 25: Single Immediate Payment Initiation submitted by DS - NPA CIS ignores in-flight payment**

#### 4.1.23 Single Immediate Payment Initiation submitted by DS – NPA CIS rejection due to timeout (A.3.1.4)

In this scenario, no payment response is received from the Receiving Agent within the defined timeout period. The NPA CIS rejects the payment initiation message and sends out a rejection Payment Initiation Response message to the Direct Submitter.

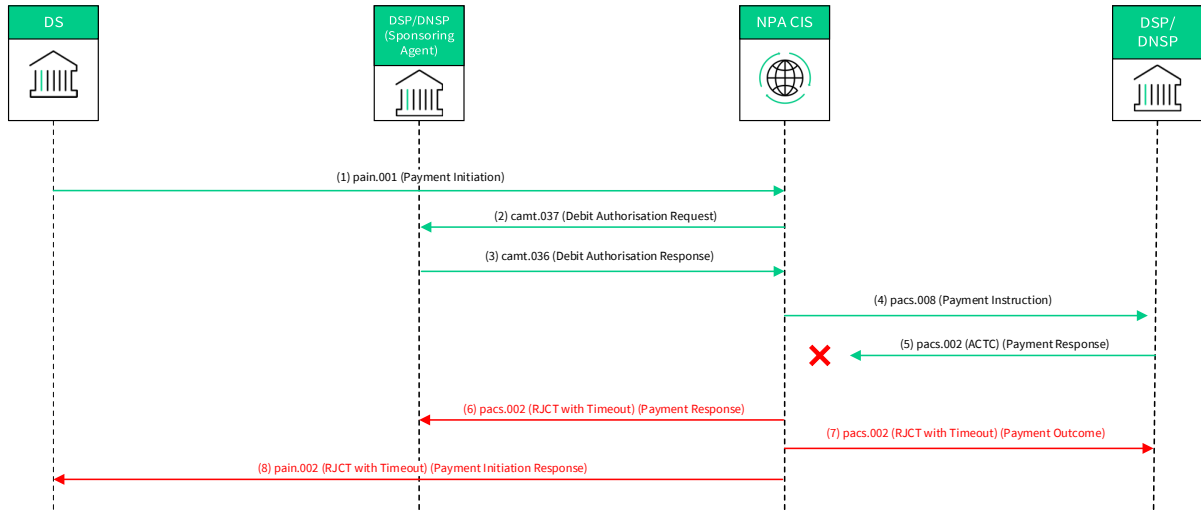

**Figure 26: Single Immediate Payment Initiation submitted by DS – NPA CIS rejection due to timeout**

#### 4.1.24 Single Immediate Payment Initiation submitted by DS – Rejected by Receiving Agent due to Technical reasons (A.3.1.5)

In this scenario, a Direct Submitter sends a Single Payment Initiation message to the NPA CIS. The NPA CIS validates the payment instruction and sends it to the Receiving Agent. The Receiving Agent rejects the payment instruction due to technical validation reasons sends out a technical rejection message. The NPA CIS sends out a rejection Payment Initiation Response message to the Direct Submitter.

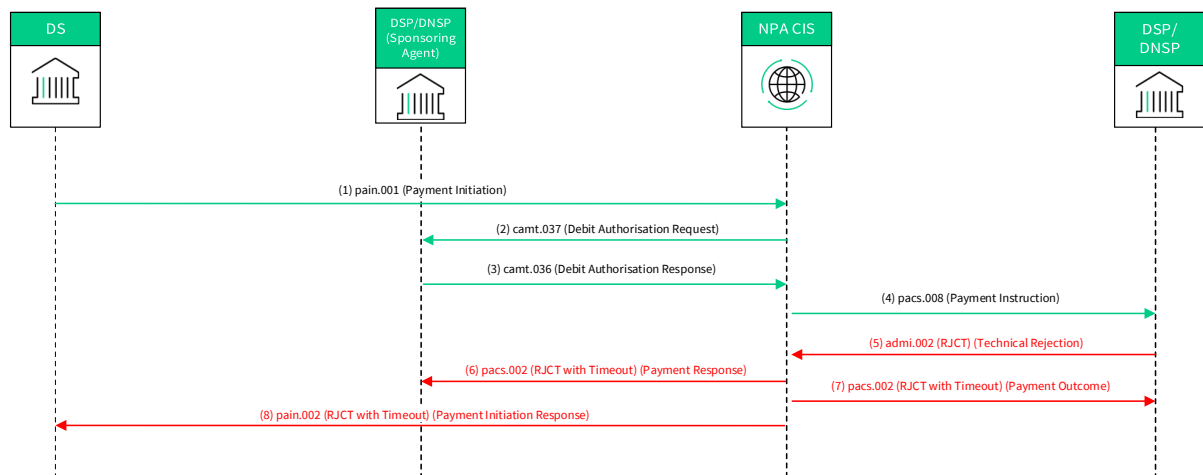

**Figure 27: Single Immediate Payment Initiation submitted by DS – Rejected by Receiving Agent due to Technical reasons**

#### 4.1.25 Single Immediate Payment Initiation submitted by DS – Rejected by Receiving Agent due to Business reasons (A.3.1.6)

In this scenario, a Direct Submitter sends a Single Payment Initiation message to the NPA CIS. The NPA validates the Payment instruction and sends it to the Receiving Agent. The Receiving Agent rejects the payment instruction due to business validation reasons. The NPA CIS sends out a rejection Payment Response message to the Direct Submitter.

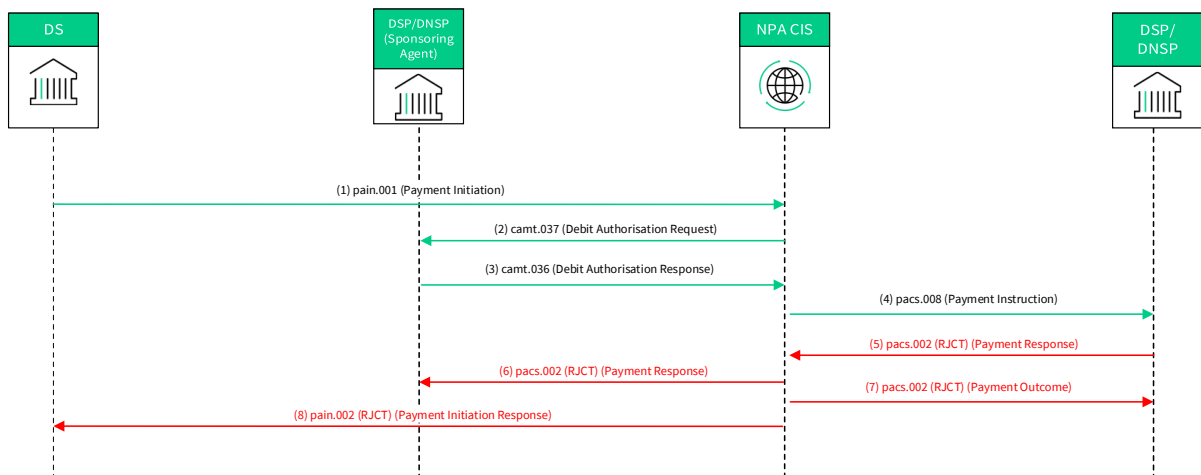

**Figure 28: Single Immediate Payment Initiation submitted by DS – Rejected by Receiving Agent due to Business reasons**

#### 4.1.26 Single Immediate Payment Initiation submitted by DS - Not received by the NPA CIS – Repeat (A.3.1.7)

In this scenario, a Single Payment Initiation message sent by the Direct Submitter is not received by NPA CIS. The payment instruction is then resent by Direct Submitter with “Possible Duplicate = TRUE” and processed successfully by NPA CIS.

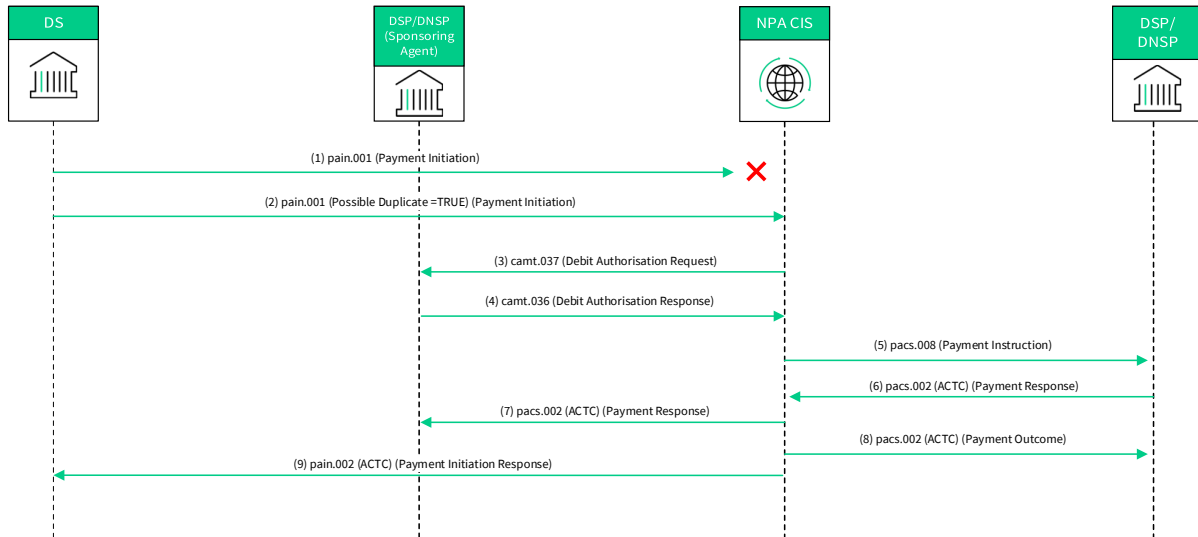

**Figure 29: Single Immediate Payment Initiation submitted by DS - Not received by the NPA CIS – Repeat**

#### 4.1.27 Single Immediate Payment Initiation submitted by DS - Payment Initiation Response not received by the Direct Submitter – Repeat (A.3.1.7)

In this scenario, the Direct Submitter did not receive the Payment Initiation Response sent by the NPA CIS. The payment instruction is resent by Direct Submitter with “Possible Duplicate =TRUE”. The NPA CIS checks that the payment is processed and sends back the original Payment Initiation Response to the Direct Submitter.

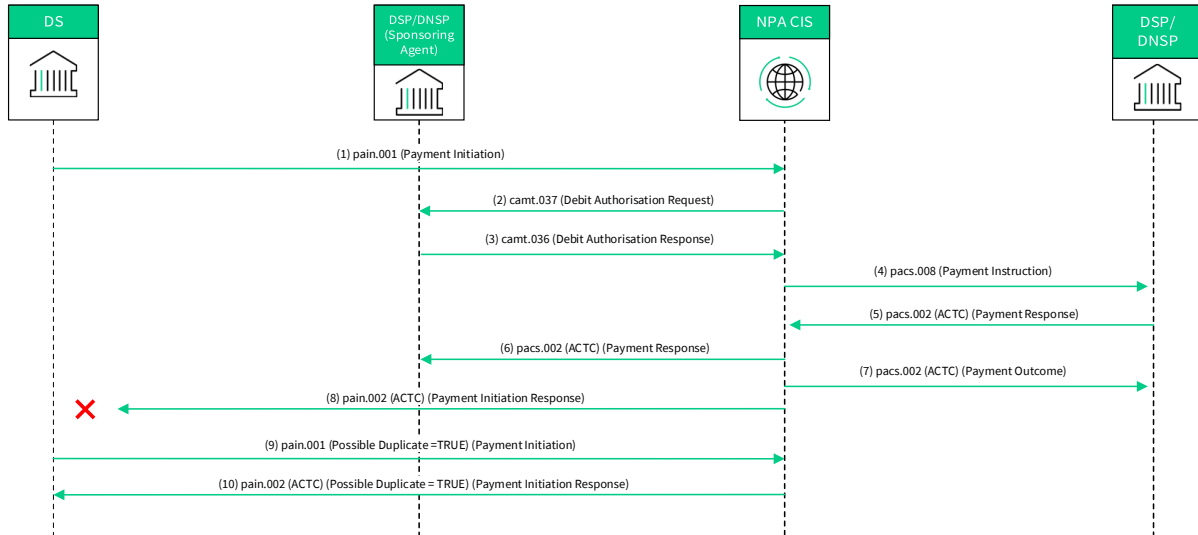

**Figure 30: Single Immediate Payment Initiation submitted by DS - Payment Initiation Response not received by the Direct Submitter – Repeat**

#### 4.1.28 Single Immediate Payment Initiation submitted by TSP (DS) – Accepted (A.4.1.1)

In this scenario, a Direct Submitter submits a Single Payment Initiation message to the NPA CIS via a TSP which is Accepted by the Receiving Agent.

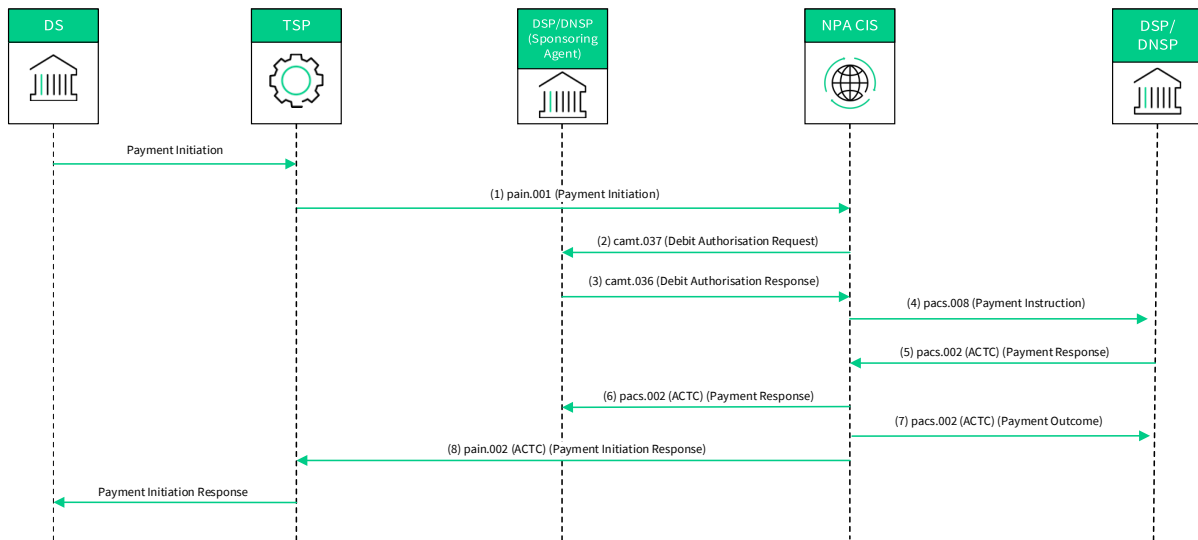
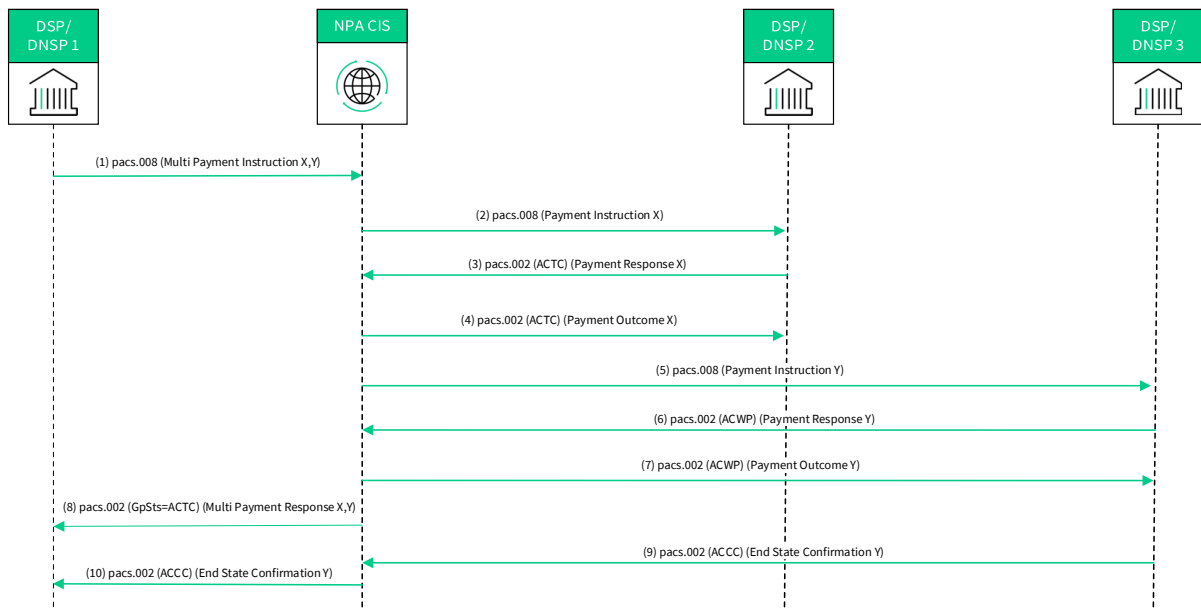

**Figure 31: Single Immediate Payment Initiation submitted by TSP (DS) – Accepted**

## 4.2 Group B – Multi/File

### 4.2.1 Multi/File Immediate Payment Instruction submitted by DSP/DNSP – Accepted and Conditionally Accepted (B.1.1.1)

In this scenario, a Sending Agent submits a Multi/File Payment instruction, containing two payments (X and Y), to the NPA CIS which are Accepted (X) and Conditionally Accepted (Y) by the Receiving Agents.



**Figure 32: Multi/File Immediate Payment Instruction submitted by DSP/DNSP – Accepted and Conditionally Accepted**

## 4.2.2 Multi/File SOP/FDP Payment Instruction submitted by DSP/DNSP – Accepted and Conditionally Accepted (B.1.1.1)

In this scenario, a Sending Agent submits a Multi/File SOP/FDP Payment instruction, containing two payments (X and Y), to the NPA CIS which are Accepted (X) and Conditionally Accepted (Y) by the Receiving Agents.

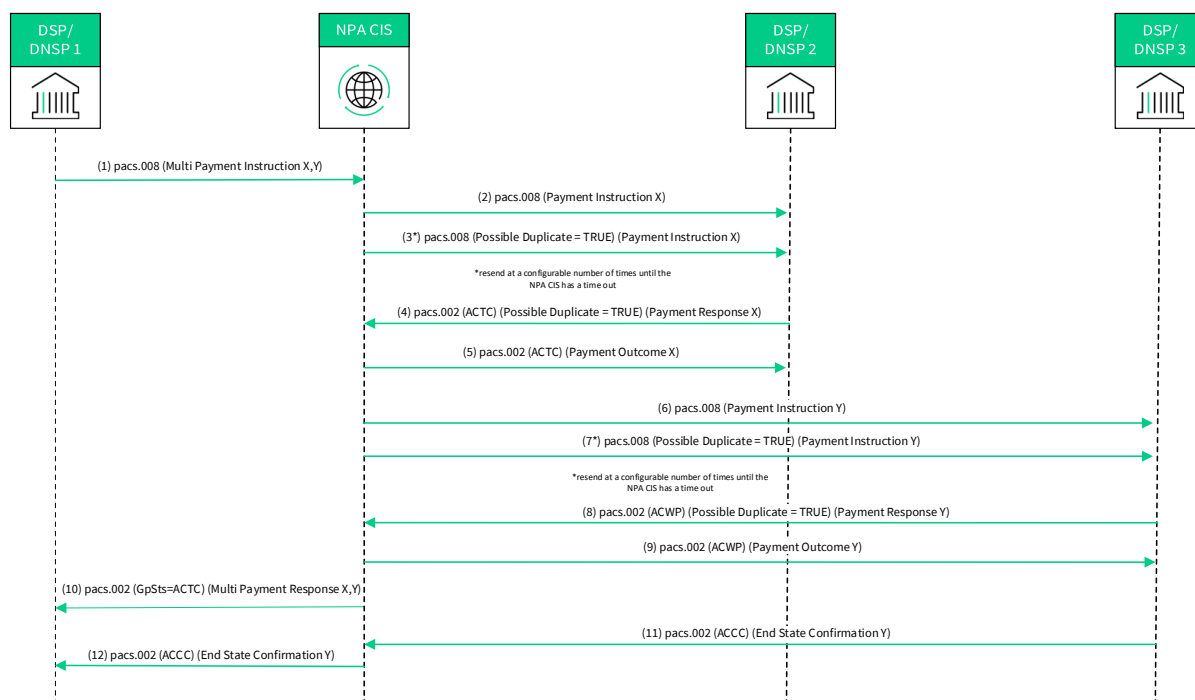

**Figure 33: Multi/File SOP/FDP Payment Instruction submitted by DSP/DNSP – Accepted and Conditionally Accepted**

### 4.2.3 Multi/File Immediate Payment Instruction submitted by DSP/DNSP – Partially Accepted (B.1.1.2)

In this scenario, a Sending Agent submits a Multi/File Payment instruction, containing two payments (X and Y), to the NPA CIS which are Accepted (X) and Rejected (Y) by the Receiving Agents. The NPA CIS sends a Multi/File Payment Response with Group Status code 'PART' to the Sending Agent.

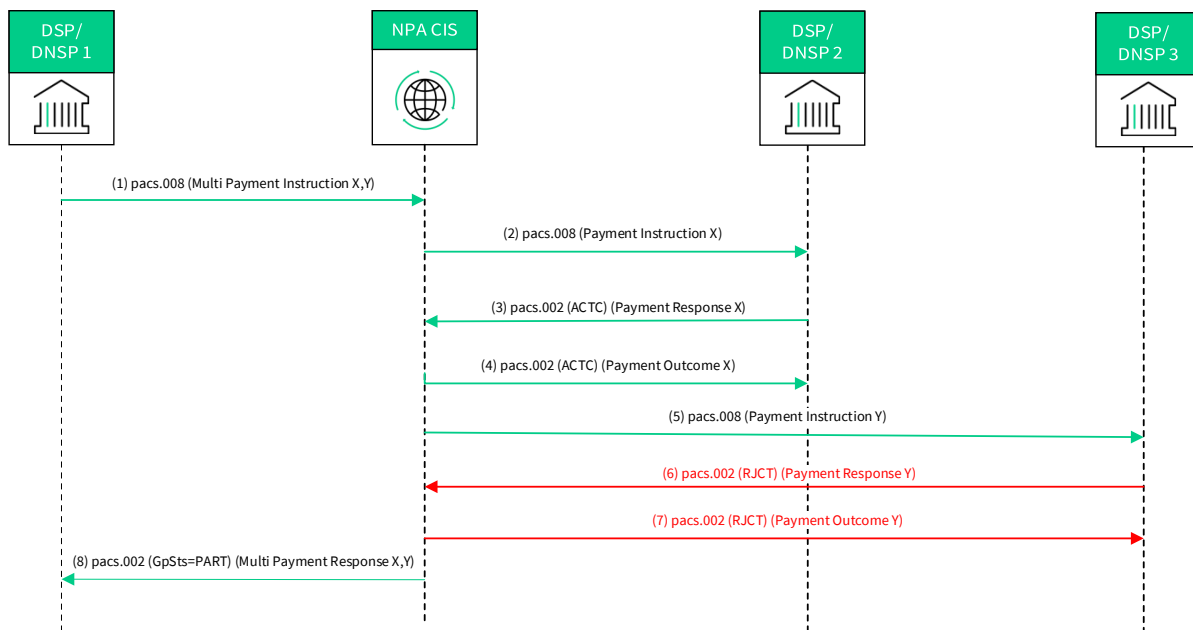

**Figure 34: Multi/File Immediate Payment Instruction submitted by DSP/DNSP – Partially Accepted**

#### 4.2.4 Multi/File Immediate Payment Instruction submitted by DSP/DNSP – Rejected by NPA CIS due to Technical reasons (B.1.1.3)

In this scenario, a Sending Agent submits a Multi/File Payment Instruction, containing two payments (X and Y), to the NPA CIS. The NPA CIS rejects the Multi/File Payment Instruction due to technical validation reasons and sends out a technical rejection message to the Sending Agent.

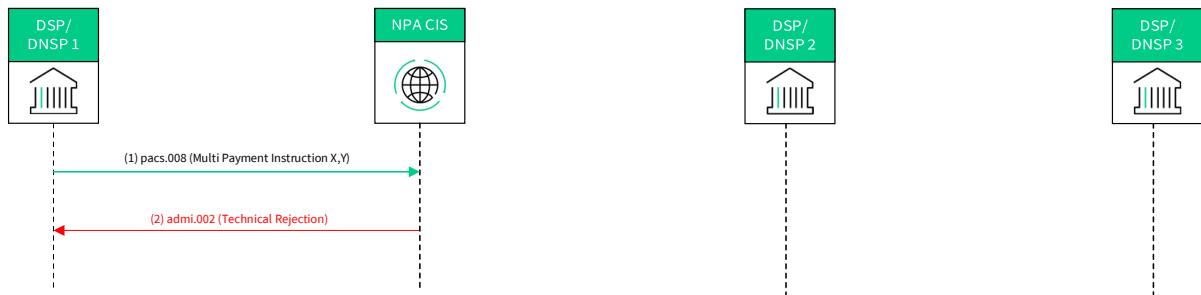

**Figure 35: Multi/File Immediate Payment Instruction submitted by DSP/DNSP – Rejected by NPA CIS due to Technical reasons**

#### 4.2.5 Multi/File Immediate Payment Instruction submitted by DSP/DNSP – Rejected by NPA CIS due to Business reasons (B.1.1.4)

In this scenario, a Sending Agent submits a Multi/File Payment Instruction, containing two payments (X and Y), to the NPA CIS. The NPA CIS rejects the Multi/File Payment Instruction due to business validation reasons and sends out a rejection message to the Sending Agent.



**Figure 36: Multi/File Immediate Payment Instruction submitted by DSP/DNSP – Rejected by NPA CIS due to Business reasons**

#### 4.2.6 Multi/File Immediate Payment Instruction submitted by TSP (DSP/DNSP) – Accepted (B.2.1.1)

In this scenario, a Sending Agent submits a Multi/File Payment instruction, containing two payments (X and Y), to the NPA CIS via a TSP which are Accepted (X and Y) by the Receiving Agents.

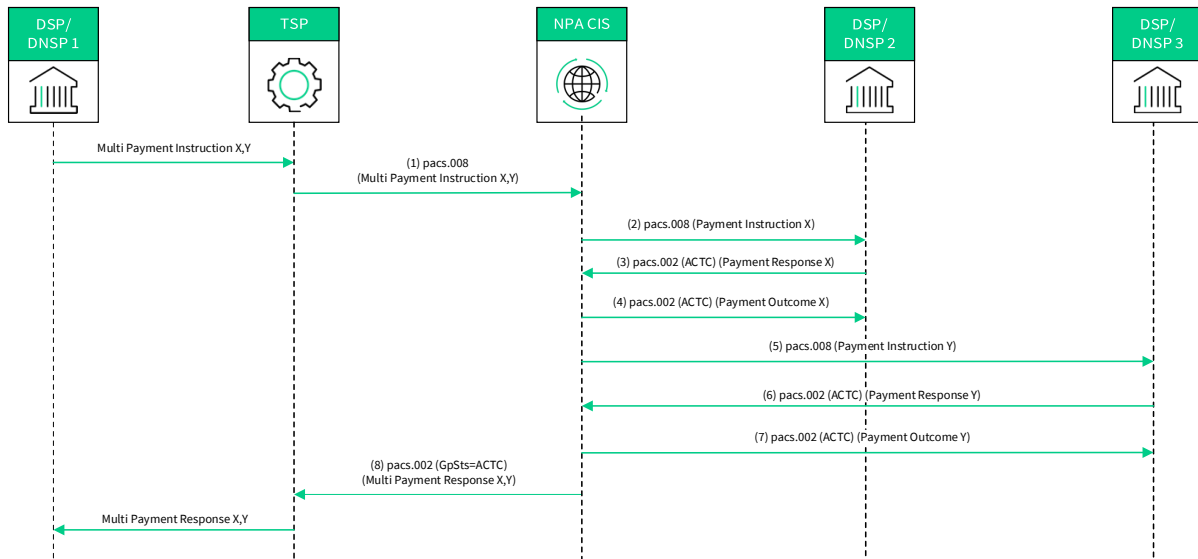

**Figure 37: Multi/File Immediate Payment Instruction submitted by TSP (DSP/DNSP) – Accepted**

#### 4.2.7 Multi/File Immediate Payment Initiation submitted by DS – Accepted and Conditionally Accepted (B.3.1.1)

In this scenario, a Direct Submitter submits a Multi/File Payment Initiation message, containing two payments (X and Y), to the NPA CIS which are Accepted (X) and Conditionally Accepted (Y) by the Receiving Agents.

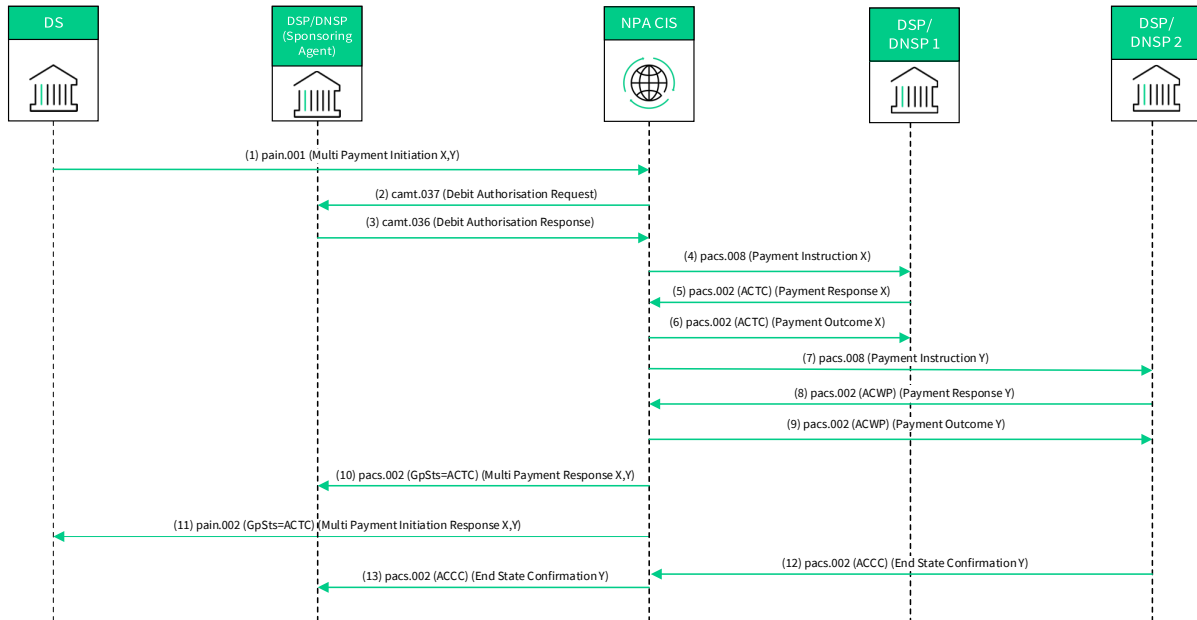

**Figure 38: Multi/File Immediate Payment Initiation submitted by DS – Accepted and Conditionally Accepted**

#### 4.2.8 Multi/File FDP Payment Initiation submitted by DS – Accepted and Conditionally Accepted (B.3.1.1)

In this scenario, a Direct Submitter submits a Multi/File Forward Dated Payment Initiation message, containing two payments (X and Y), to the NPA CIS which are Accepted (X) and Conditionally Accepted (Y) by the Receiving Agents.

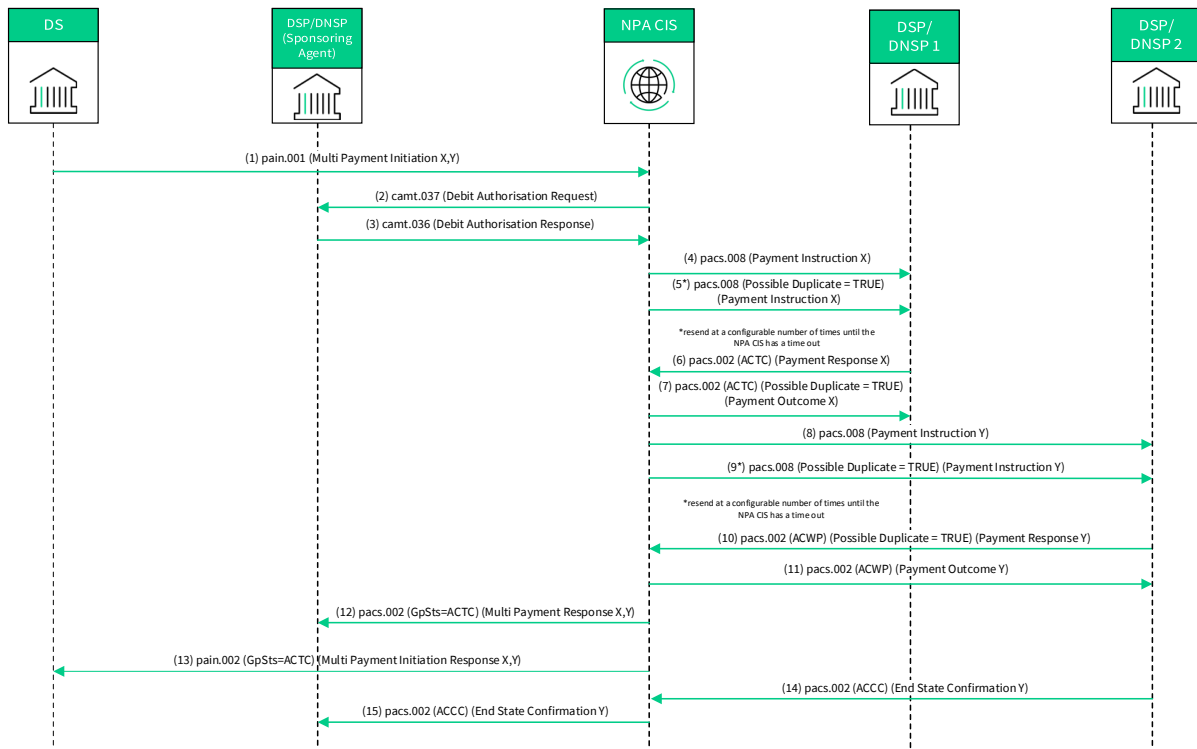

**Figure 39: Multi/File FDP Payment Initiation submitted by DS – Accepted and Conditionally Accepted**

#### 4.2.9 Multi/File Immediate Payment Initiation submitted by DS – Partially Accepted (B.3.1.2)

In this scenario, a Direct Submitter submits a Multi/File Payment Initiation message, containing two payments (X and Y), to the NPA CIS which are Accepted (X) and Rejected (Y) by the Receiving Agents. The NPA CIS sends a Multi/File Payment Initiation Response message with Group Status code 'PART' to the Direct Submitter.

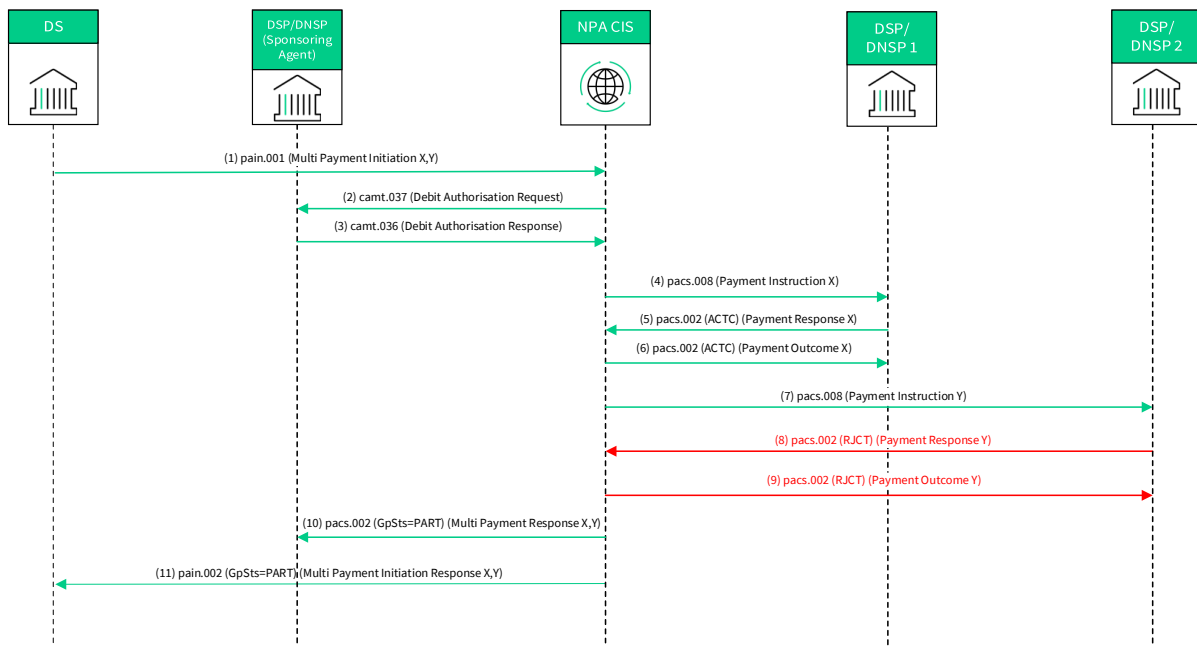

**Figure 40: Multi/File Immediate Payment Initiation submitted by DS – Partially Accepted**

#### 4.2.10 Multi/File Immediate Payment Initiation submitted by DS – Rejected by NPA CIS due to Technical reasons (B.3.1.3)

In this scenario, a Direct Submitter submits a Multi/File Payment Initiation message to the NPA CIS. The NPA CIS rejects the Multi/File Payment Initiation due to technical validation reasons and sends out a technical rejection message to the Direct Submitter.

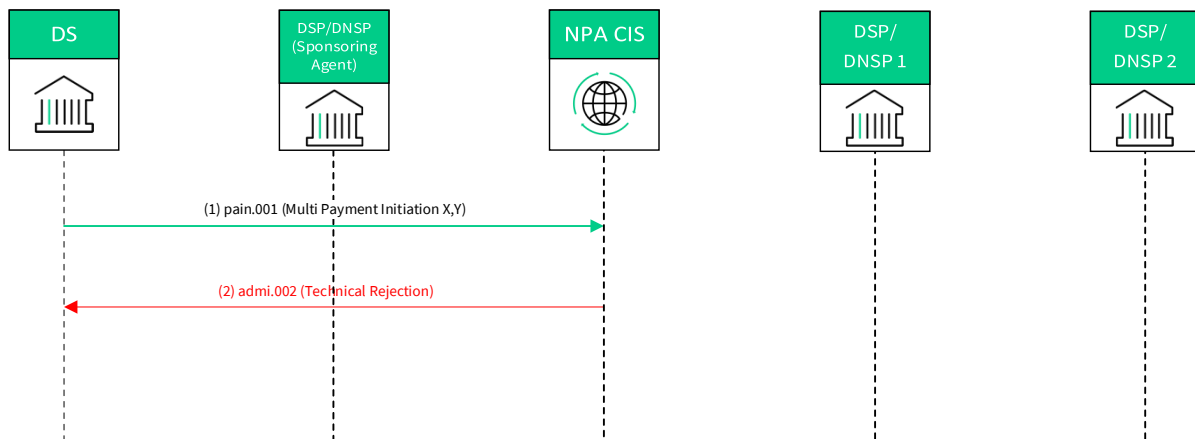

**Figure 41: Multi/File Immediate Payment Initiation submitted by DS – Rejected by NPA CIS due to Technical reasons**

#### 4.2.11 Multi/File Immediate Payment Initiation submitted by DS – Rejected by NPA CIS due to Business reasons (B.3.1.4)

In this scenario, a Direct Submitter submits a Multi/File Payment Initiation message to the NPA CIS. The NPA CIS rejects the Multi/File Payment Initiation message due to business validation reasons and sends out a rejection payment initiation response to the Direct Submitter.

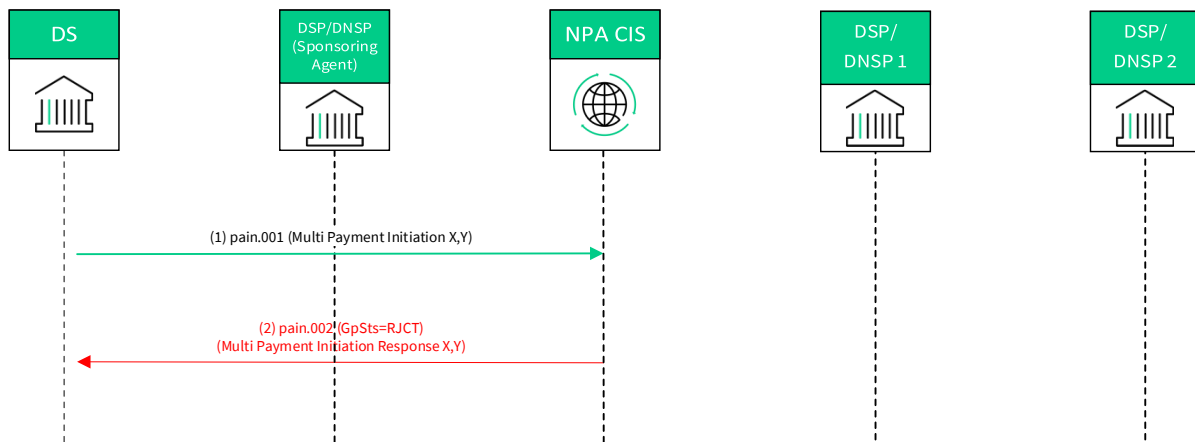

**Figure 42: Multi/File Immediate Payment Initiation submitted by DS – Rejected by NPA CIS due to Business reasons**

#### 4.2.12 Multi/File Immediate Payment Initiation submitted by TSP (DS) – Accepted (B.4.1.1)

In this scenario, a Direct Submitter submits a Multi/File Payment Initiation message, containing two payments (X and Y), to the NPA CIS via a TSP which are Accepted (X and Y) by the Receiving Agents.

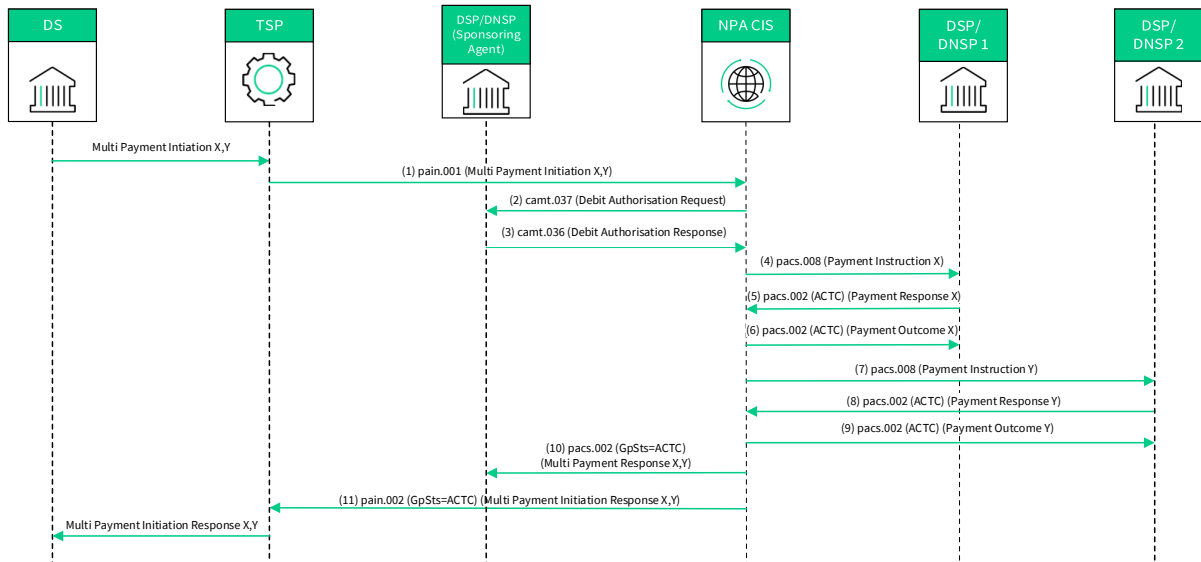
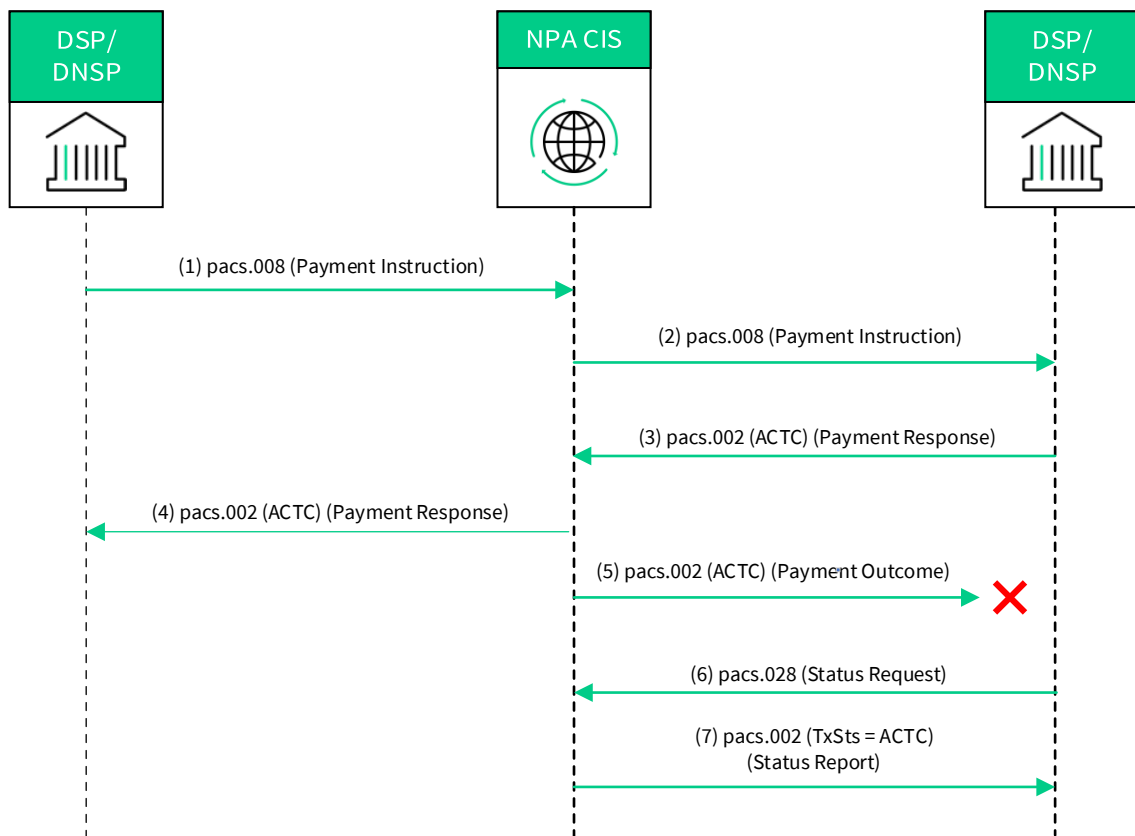

**Figure 43: Multi/File Immediate Payment Initiation submitted by TSP (DS) – Accepted**

## 4.3 Additional Scenarios

### 4.3.1 Single Status Request submitted by DSP/DNSP – Accepted

A Sending or Receiving Agent of an Original Single Payment Instruction can submit a Status Request to the NPA CIS. However, the most common use of the Status Request is reflected in the diagram below and the scenarios covered in this document are non-exhaustive. The Receiving Agent does not receive a Payment Outcome and then sends a Status Request to the NPA CIS. The NPA CIS responds with the status of the Original Payment Instruction.



**Figure 44: Single Status Request submitted by DSP/DNSP – Accepted**

### 4.3.2 Multi/File Status Request submitted by DSP/DNSP – Accepted

A Sending Agent of an Original Multi/File Payment Instruction can submit a Status Request to the NPA CIS. In this scenario, the Sending Agent receives the group status of the Original Multi/File Payment Instruction.

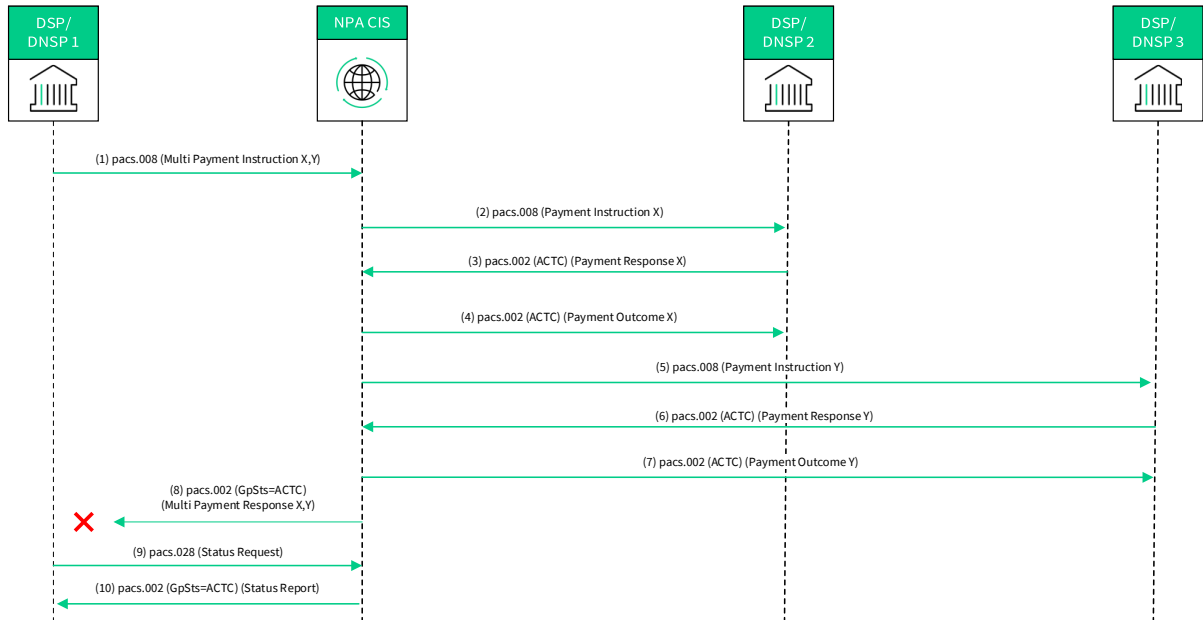

**Figure 45: Multi/File Status Request submitted by DSP/DNSP - Accepted**

### 4.3.3 Single Status Request submitted by DS – Accepted

A Direct Submitter of an Original Single Payment Initiation can submit a Status Request to the NPA CIS. In this scenario, the Direct Submitter receives the status of the Original Single Payment Initiation.

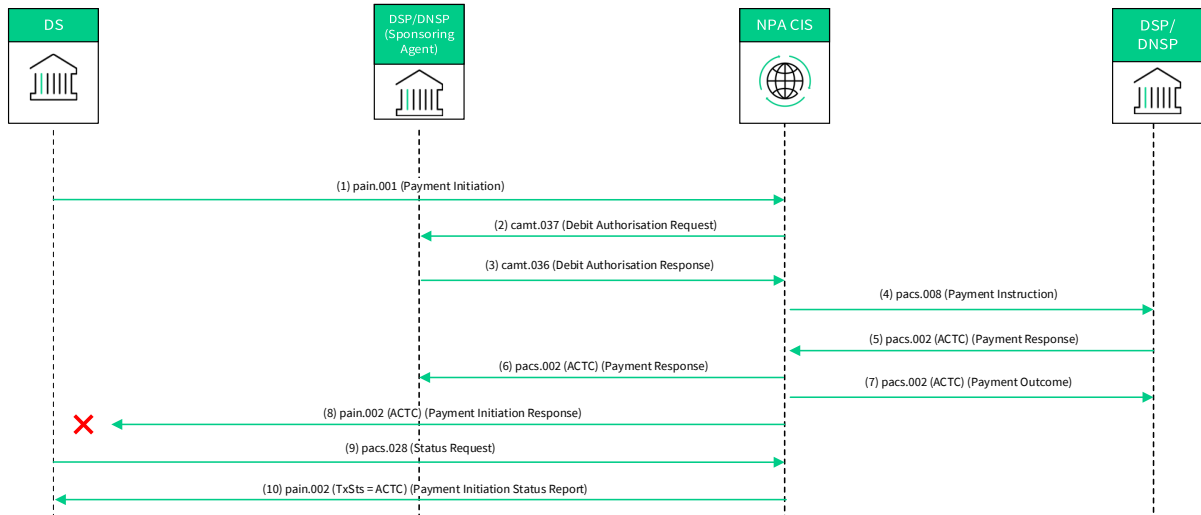
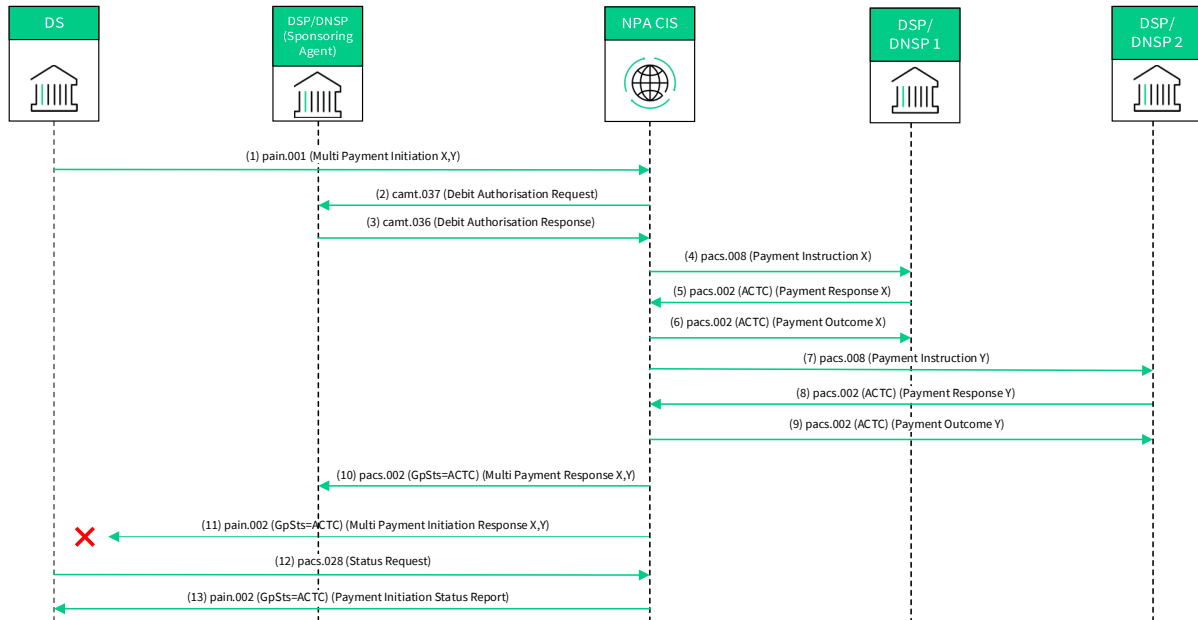

Figure 46: Single Status Request submitted by DS – Accepted

#### 4.3.4 Multi/File Status Request submitted by DS – Accepted

A Direct Submitter of an Original Multi/File Payment Initiation can submit a Status Request to the NPA CIS. In this scenario, the Direct Submitter receives the group status of the Original Multi/File Payment Initiation.



**Figure 47: Multi/File Status Request submitted by DS - Accepted**

## 5 Appendix

### 5.1 Tables

<b>Table 1: Change History for Message Sequence Diagrams</b> .....	7
<b>Table 2: Terms for Roles and Submission Types</b> .....	9

### 5.2 Figures

<b>Figure 1: Payment Flow Categorisation Diagram (up to Level 3)</b> .....	10
<b>Figure 2: Payment Flow Categorisation Diagram (up to Level 4 Single)</b> .....	10
<b>Figure 3: Payment Flow Categorisation Diagram (up to Level 4 Multi/File)</b> .....	11
<b>Figure 4: Single Immediate Payment instruction submitted by DSP/DNSP - Accepted</b> .....	12
<b>Figure 5: Single SOP/FDP instruction submitted by DSP/DNSP – Accepted</b> .....	13
<b>Figure 6: Single Immediate Payment instruction submitted by DSP/DNSP - Conditionally Accepted</b> .....	14
<b>Figure 7: Single Immediate Payment instruction submitted by DSP/DNSP – Rejected by NPA CIS due to Technical reasons</b> .....	15
<b>Figure 8: Single Immediate Payment instruction submitted by DSP/DNSP – Rejected by NPA CIS due to Business reasons</b> .....	16
<b>Figure 9: Single Immediate Payment instruction submitted by DSP/DNSP – Rejected by NPA CIS due to a Duplicate</b> .....	17
<b>Figure 10: Single Immediate Payment instruction submitted by DSP/DNSP – NPA CIS ignores in-flight payment</b> .....	18
<b>Figure 11: Single Immediate Payment instruction submitted by DSP/DNSP – NPA CIS rejection due to timeout</b> .....	19
<b>Figure 12: Single Immediate Payment instruction submitted by DSP/DNSP – Rejected by Receiving Agent due to Technical reasons</b> .....	20
<b>Figure 13: Single Immediate Payment instruction submitted by DSP/DNSP Rejected by Receiving Agent due to Business reasons</b> .....	21
<b>Figure 14: Single Immediate Payment instruction submitted by DSP/DNSP - Not received by the NPA CIS – Repeat</b> .....	22
<b>Figure 15: Single Immediate Payment instruction submitted by DSP/DNSP - Payment Response not received by the Sending Agent – Repeat</b> .....	23
<b>Figure 16: Single Immediate Payment instruction submitted by DSP/DNSP - Redirection by NPA CIS (CASS)</b> .....	24
<b>Figure 17: Single Payment Return submitted by DSP/DNSP – Accepted</b> .....	25
<b>Figure 18: Single Immediate Payment instruction submitted by TSP (DSP/DNSP) – Accepted</b> .....	26
<b>Figure 19: Single Immediate Payment Initiation submitted by DS – Accepted</b> .....	27
<b>Figure 20: Single FDP Payment Initiation submitted by DS – Accepted</b> .....	28
<b>Figure 21: Single Immediate Payment Initiation submitted by DS – Conditionally Accepted</b> .	29
<b>Figure 22: Single Immediate Payment Initiation submitted by DS – Rejected by NPA CIS due to Technical reasons</b> .....	30
<b>Figure 23: Single Immediate Payment Initiation submitted by DS – Rejected by NPA CIS due to Business reasons</b> .....	31
<b>Figure 24: Single Immediate Payment Initiation submitted by DS – Rejected by NPA CIS due to a Duplicate</b> .....	32
<b>Figure 25: Single Immediate Payment Initiation submitted by DS - NPA CIS ignores in-flight payment</b> .....	33

<b>Figure 26: Single Immediate Payment Initiation submitted by DS – NPA CIS rejection due to timeout</b> .....	34
<b>Figure 27: Single Immediate Payment Initiation submitted by DS – Rejected by Receiving Agent due to Technical reasons</b> .....	35
<b>Figure 28: Single Immediate Payment Initiation submitted by DS – Rejected by Receiving Agent due to Business reasons</b> .....	36
<b>Figure 29: Single Immediate Payment Initiation submitted by DS - Not received by the NPA CIS – Repeat</b> .....	37
<b>Figure 30: Single Immediate Payment Initiation submitted by DS - Payment Initiation Response not received by the Direct Submitter – Repeat</b> .....	38
<b>Figure 31: Single Immediate Payment Initiation submitted by TSP (DS) – Accepted</b> .....	39
<b>Figure 32: Multi/File Immediate Payment Instruction submitted by DSP/DNSP – Accepted and Conditionally Accepted</b> .....	40
<b>Figure 33: Multi/File SOP/FDP Payment Instruction submitted by DSP/DNSP – Accepted and Conditionally Accepted</b> .....	41
<b>Figure 34: Multi/File Immediate Payment Instruction submitted by DSP/DNSP – Partially Accepted</b> .....	42
<b>Figure 35: Multi/File Immediate Payment Instruction submitted by DSP/DNSP – Rejected by NPA CIS due to Technical reasons</b> .....	43
<b>Figure 36: Multi/File Immediate Payment Instruction submitted by DSP/DNSP – Rejected by NPA CIS due to Business reasons</b> .....	44
<b>Figure 37: Multi/File Immediate Payment Instruction submitted by TSP (DSP/DNSP) – Accepted</b> .....	45
<b>Figure 38: Multi/File Immediate Payment Initiation submitted by DS – Accepted and Conditionally Accepted</b> .....	46
<b>Figure 39: Multi/File FDP Payment Initiation submitted by DS – Accepted and Conditionally Accepted</b> .....	47
<b>Figure 40: Multi/File Immediate Payment Initiation submitted by DS – Partially Accepted</b> ....	48
<b>Figure 41: Multi/File Immediate Payment Initiation submitted by DS – Rejected by NPA CIS due to Technical reasons</b> .....	49
<b>Figure 42: Multi/File Immediate Payment Initiation submitted by DS – Rejected by NPA CIS due to Business reasons</b> .....	50
<b>Figure 43: Multi/File Immediate Payment Initiation submitted by TSP (DS) – Accepted</b> .....	51
<b>Figure 44: Single Status Request submitted by DSP/DNSP – Accepted</b> .....	52
<b>Figure 45: Multi/File Status Request submitted by DSP/DNSP - Accepted</b> .....	53
<b>Figure 46: Single Status Request submitted by DS – Accepted</b> .....	54
<b>Figure 47: Multi/File Status Request submitted by DS - Accepted</b> .....	55

